

SNMP Agent

Simple Network Management Protocol

Supplement to the “Functional Description and Specifications Module IE”

CONTENTS

A1	REVISION HISTORY	
A2	COPYRIGHT	
A3	GENERAL REMARKS	
1	SNMP	3
1.1	OVERVIEW	3
1.2	THE MIB FILE	4
1.3	COMMUNITIES	7
1.4	MONITORING	7
1.5	OID	8
1.6	TRAPS	9
1.7	CONFIGURATION	10
1.7.1	Web Interface	10
1.7.2	Enable/Disable Traps	10

A1 Revision History

No.	Date	Subject
0.n		Preliminary documents, changes without notice.
1.0	December 04, 2006	First released document.
1.1	April 02, 2008	MIB file can be composed of functional groups.

A2 Copyright

Copyright © Alpermann+Velte Electronic Engineering GmbH 2005. All rights reserved. No part of this publication may be reproduced, translated into another language, stored in a retrieval system, or transmitted, in any form or by any means, electronic, mechanical, photocopying, recording, or otherwise without the prior written consent of Alpermann+Velte Electronic Engineering GmbH.

Printed in Germany.

Technical changes are reserved.

All brand and product names mentioned herein are used for identification purposes only, and are trademarks or registered trademarks of their respective holders.

Information in this publication replaces all previously published information. Alpermann+Velte Electronic Engineering GmbH assumes no responsibility for errors or omissions. Neither is any liability assumed for damages resulting from the use of the information contained herein.

For further information please contact your local dealer or:

Alpermann+Velte

Electronic Engineering GmbH
Otto-Hahn-Str. 42
D-42369 Wuppertal
Phone: ++49 - (0)202 – 244 111 0
Fax: ++49 - (0)202 – 244 111 5
E-Mail: info@alpermann-velte.com
Internet: <http://www.alpermann-velte.com>

A3 General Remarks

This manual is a supplement to the "Functional Description & Specifications Module IE" manual. It describes a special feature of the **IE** module realized by an optional firmware.

1 SNMP

1.1 Overview

With the SNMP option of the Rubidium IE module your rubidium system is capable of being used as a SNMP Network Element. You can easily monitor and control the system using centralized network management software.

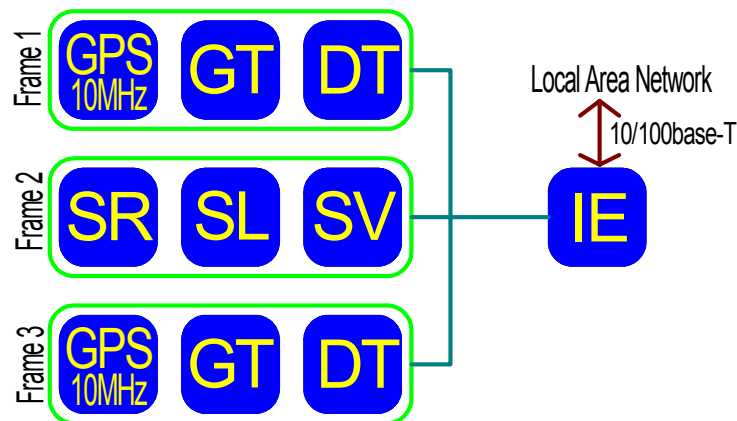

If you need detailed information about SNMP protocol you should have a look at the related documents, as RFC 1157 for example.

Basically there are three types of SNMP messages:

- GET: the management station requests status information from an agent.
- SET: the management station requests an agent to change a parameter.
- TRAP: the agent sends a message to indicate an event.

The access to a SNMP system is controlled by "communities", these are text strings included in the message. Often the text "PUBLIC" (read only) and "PRIVATE" (read and write) are used. But you can add others names or erase existing names.

Any accessible element can be uniquely identified by its OID (Object Identifier). For a group of OIDs usually a MIB file (management information base) is defined, which is a text file containing all relevant information for each single OID. For the Rubidium System the "rubidium.mib" has to be created by the user utilizing the RUBIDIUM CONFIGURATION PC program.

1.2 The MIB File

Execute "Rubidium Config.exe" on your computer. Open the *Tools* menu and select "Create MIB File ...". Please follow the instructions of the "Rubidium MIB Maker".

First step: do you want to create a new MIB file or do you want to change an existing one?

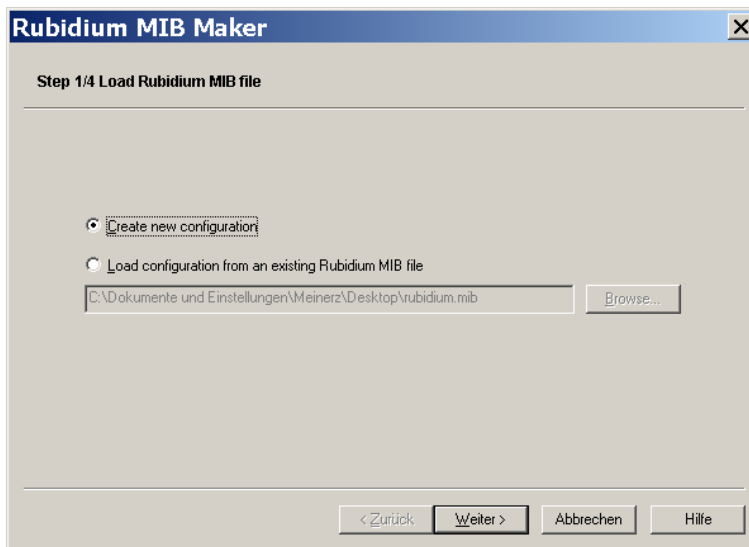

Second step: built your Rubidium system.

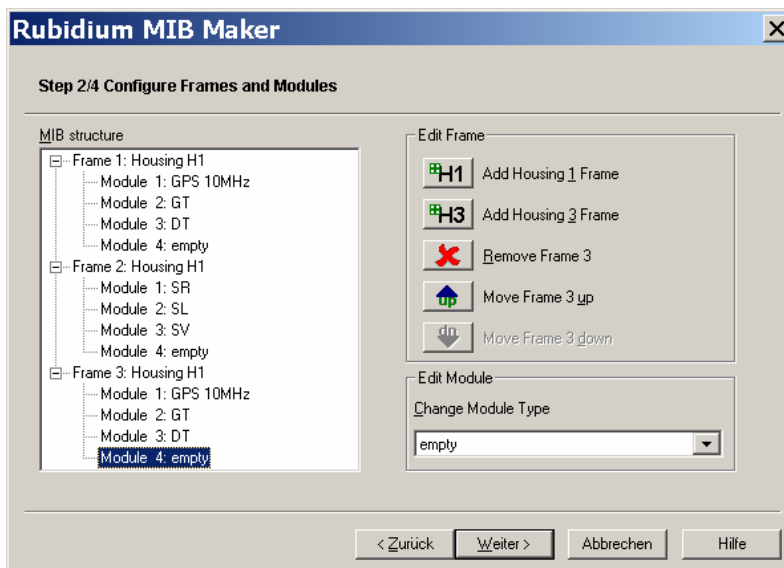

The "MIB structure" window indicates the current built system. Add or remove Rubidium frames pressing the buttons of "Edit Frame". Clicking on a module at the MIB structure enables you to select the type of the module out of the "Edit Module" dropdown list.

The structure has to correspond exactly to the real system, regarding the frame and module numbering and the type of each module.

Third step: select the functional groups and the version of the MIB file.

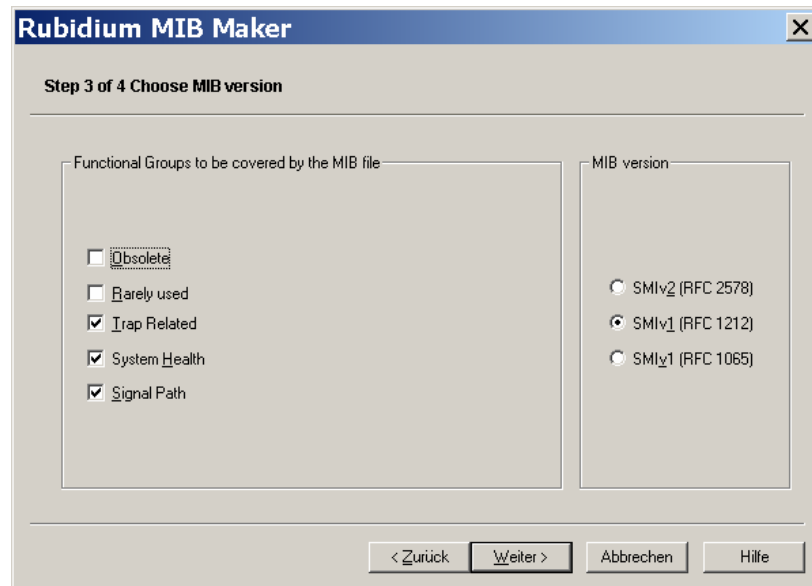

The following **Functional Groups** can be selected:

- | | |
|---------------|--|
| Signal Path | contains the most important status information to monitor the signals of the system. Especially it contains the warnings and alarms of the RUBIDIUM switcher modules. |
| System Health | contains the most important status information to monitor the general RUBIDIUM system behaviour. Especially it contains the status of the fan, of the temperature and of the power supply. |
| Trap Related | contains all the traps the modules are able to generate. |
| Rarely used | contains all the rest. It may be used for special applications only. |
| Obsolete | may be used if you want to update an existing installation which might no longer be compatible. For more information please contact <i>Alpermann+Velte</i> company. |

MIB Version: Please select a format which is compatible to your SNMP manager.

Fourth step: select the path where you want to store the MIB file.

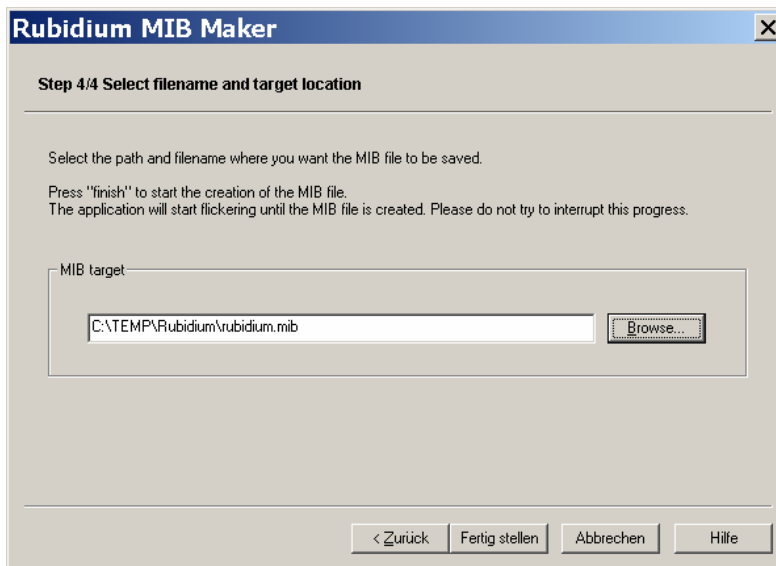

With a click on "Finish" the MIB file will be created. You will see the screen flickering, but don't worry and don't interrupt the process.

Click on the OK button at the end, the MIB file has been created successfully.

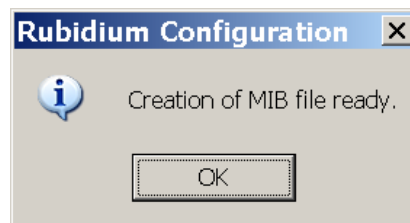

1.3 Communities

The following community strings are used by the Rubidium IE module for default. It is recommended to change them in order to avoid unwanted access by guessing these strings.

- Read Community: public
- Write Community: private

1.4 Monitoring

All status and setup information can be queried via SNMP for every module that is present in your Rubidium system. That means that you can choose between the status monitor from the IE module and your SNMP management application to control the status of your system.

How you get the setup and status information you require depends on the special SNMP monitoring software you are using. The most likely and probably best method to gain information from the MIB file is allowing your management system (or a special MIB browser) to load the MIB file and then presenting the MIB's content as a tree or something equivalent.

Example of a simple MIB browser:

The screenshot shows an SNMP MIB browser window. The address is 'uvdp:161' and the OID is '.1.3.6.1.4.1.22629.100.0.1.3.7.1.6.6.0'. The left pane shows a tree view of MIB nodes, with 'f0h1m3t7Set6SIGNAL' selected. The right pane shows a table of values for the selected node.

Name/OID	Value
f0h1m3t7SetKeysGT	0
f0h1m3t7Set6F2.0	6
f0h1m3t7Set6F1.0	5
f0h1m3t7Set6F3.0	7
f0h1m3t7Set6F4.0	8
f0h1m3t7Set6OPER.0	12
f0h1m3t7Set6SIGNAL.0	5

Node Name: f0h1m3t7Set6SIGNAL
 OID: .1.3.6.1.4.1.22629.100.0.1.3.7.1.6.6
 Syntax: INTEGER (0..20)
 Access: read-write
 Status: mandatory
 DefVal:
 Descr: SIGNAL

1.5 OID

Any setup or status information has an OID (Object Identifier). The OID consist of a fixed part and a variable part that includes the physical location of the module inside the frame and the module's type. The following table describes the OID's structure using the following OID for an example:

.1.3.6.1.4.1.22629.100.0.1.4.2.2.1.5.0

The meaning of this sample OID is shown in bold type in the table below.

Example	Name	Description
.1	.iso	Fixed part
.3	.org	Fixed part
.6	.dod	Fixed part
.1	.internet	Fixed part
.4	.private	Fixed part
.1	.enterprises	Fixed part
.22629	.alpermannVelte	Fixed part
.100	.rubidium	Fixed part
.0	FrameSingle or Frame1 ... Frame31	Single frame configuration or number of frame in multiframe configuration
.1	H1 or H3	1U frame or 3U frame
.4	Module1 ... Module4 or Module1 ... Module21	Module's number inside the 1U frame or Module's number inside the 3U frame
.2	AT, DT , GT, ...	Module's type
.2	Set or Sta	Setup or Status
.1	System, Keys , LtcR, ...	Functional group
.5	Name, OPER , Rate, ...	Function

1.6 Traps

Several traps can be generated and sent to your network management application. The kind of trap depends on the type of the module. Traps can be transmitted to indicate an event quickly.

In particular, the following trap-events are available:

- Any Module
 - Cold Boot
 - Config
- Module Switcher (SL / SI / SV / SR):
 - System Error
 - System Failure
 - Changeover
 - Signal Failure
 - Signal Warning

Additionally, the IE module can send traps for special events, for example on rebooting, community changing and some security related events. When you first set up your network, you may want to generate a test trap to test if all settings are correct and ready to work. You may use the "Config" trap for this purpose. It's generated every time you try to connect to or disconnect from a module using the "Rubidium Config" software via the PC (RS232) connector.

1.7 Configuration

1.7.1 Web Interface

All configuration needed can be made via the web interface of your IE module. Just type the IP address in the address field of your browser as described in the manual of IE module. Then choose "Configuration", then the red button for the IE module configuration, then "SNMP", and follow the menu.

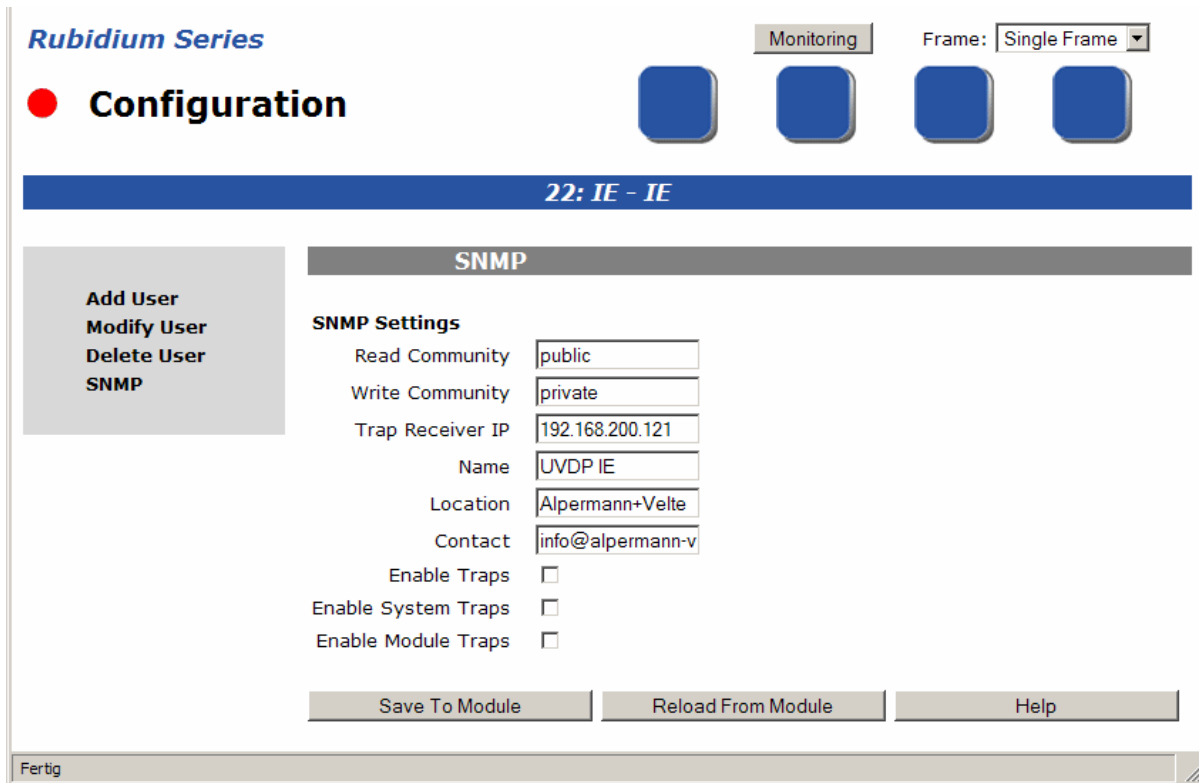

Here is a list of the most important features available by the web interface:

- View and edit Community names
- Configure the IP-address for the trap receiver
- Set system information's
- Enable / disable sending of traps in general
- Enable / disable sending of individual traps

1.7.2 Enable/Disable Traps

Traps can be configured (enabled/disabled) via the SNMP protocol as well. Just use the SNMP-Set command to send 1 or 0 on the trap you want to enable or disable. You'll find the trap enable bits in the "System" part of each module.