

Option "I"

Version: 3.0

August 3, 2011

RUB GT/GL/GI with IRIG-B Input

Option "I":

GT/GL: IRIG-B to Time Code Converter

GI: IRIG-B to IRIG-B Converter

Supplement to the "Functional Description & Specifications" Manual
of Module GT or GL or GI

CONTENTS

A1	REVISION HISTORY	
A2	COPYRIGHT	
A3	GENERAL REMARKS	
1	GENERAL DESCRIPTION	3
2	SPECIFICATIONS AND CONNECTION	3
3	CONFIGURATION	4
3.1	IRIG FORMATS	4
3.2	TIME ZONE OF REFERENCE AND LOCAL TIME ZONE	5
3.3	IRIG TELEGRAM	6
3.4	STATUS LEADS	7

A1 Revision History

No.	Date	Subject
1.0	April 28, 2005	First released document.
1.1	August 19, 2005	Revised.
1.2	August 25, 2005	IRIG-B/AFNOR. Technical data revised.
2.0	October 06, 2008	This option for GI.
2.1	December 07, 2009	This option for GL.
3.0	August 03, 2011	Completely revised.

A2 Copyright

Copyright © Alpermann+Velte Electronic Engineering GmbH 2002. All rights reserved. No part of this publication may be reproduced, translated into another language, stored in a retrieval system, or transmitted, in any form or by any means, electronic, mechanical, photocopying, recording, or otherwise without the prior written consent of Alpermann+Velte Electronic Engineering GmbH.

Printed in Germany.

Technical changes are reserved.

All brand and product names mentioned herein are used for identification purposes only, and are trademarks or registered trademarks of their respective holders.

Information in this publication replaces all previously published information. Alpermann+Velte Electronic Engineering GmbH assumes no responsibility for errors or omissions. Neither is any liability assumed for damages resulting from the use of the information contained herein.

For further information please contact your local dealer or:

Alpermann+Velte

Electronic Engineering GmbH

Otto-Hahn-Str. 42

D-42369 Wuppertal

Phone: ++49 - (0)202 – 244 111 0

Fax: ++49 - (0)202 – 244 111 5

E-Mail: info@alpermann-velte.com

Internet: <http://www.alpermann-velte.com>

A3 General Remarks

This manual is a supplement to the "Functional Description & Specifications" of module GT or GL or GI. It describes a special function of the GT/GL/GI module realized by an optional firmware. A module with this special option may have not all the functions as there are in a standard module.

The latest document describes the functions of the latest module's software. You can download the latest software version from:

http://www.alpermann-velte.com/serv_e/software_e/software_e.html.

1 General Description

With this option the module receives a time & date reference via an externally connected IRIG-B signal. The time zone of the reference input is selectable. Time & date synchronises the internal clock of the module.

If the main operating mode TIME is selected, the time of the output signals is precisely synchronized with external IRIG-B reference. The time zone of the output signals (= local time zone) is adjustable by selecting offsets and Daylight Saving Time.

Preferable the phase synchronisation of the signal output uses a second pulse (derived from the IRIG-B input). In this case the module operates as a perfect IRIG-B to LTC converter (GT or GL module) or IRIG-B to IRIG-B converter (GI module), phase-locked to the reference mark of the IRIG-B code.

The output of the GT or GL module can be synchronised to a video signal as well. In this case the time code output (LTC and VITC) will be locked to the video source. This set-up is done utilizing the 'Generate' page of a Rubidium Configuration Tool.

2 Specifications and Connection

Supported Formats	IRIG-B: Amplitude modulated 1 kHz carrier signal, balanced. IRIG-B 123 or IRIG-B 127 according to IRIG STANDARD 200-04; AFNOR time code according to AFNOR NF S 87-500.
Connector	RJ45: Signals REF_IN_A/REF_IN_B
Input	Balanced or unbalanced signals Impedance: 680 Ω Mark Amplitude: 1 Vpp to 8 Vpp Space Amplitude: 0.5 Vpp to 4 Vpp Mark-to-Space Ratio: 2/1 to 6/1

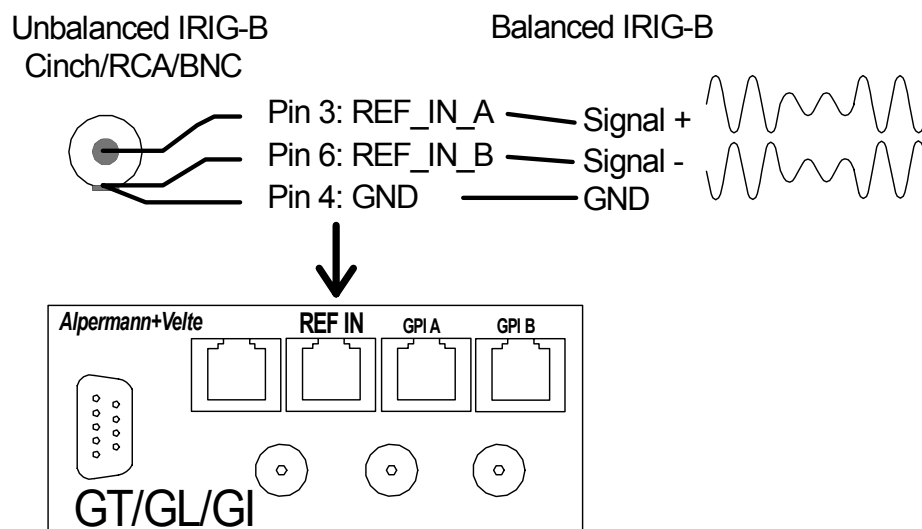

3 Configuration

Utilise the PC program "RUBIDIUM CONFIGURATION" or the RUBIDIUM SERIES HTTP server to set-up the module according to your application. If the "Factory Settings" has been applied the module operates with the following configuration:

- Main operating mode = TIME.
- Reference Source = IRIG-B.
- Sync Mode = Second Pulse (derived from the IRIG-B signal).

3.1 IRIG Formats

At the 'Reference' page of the configuration tool, three formats can be selected. Please select according to the format of the input signal.

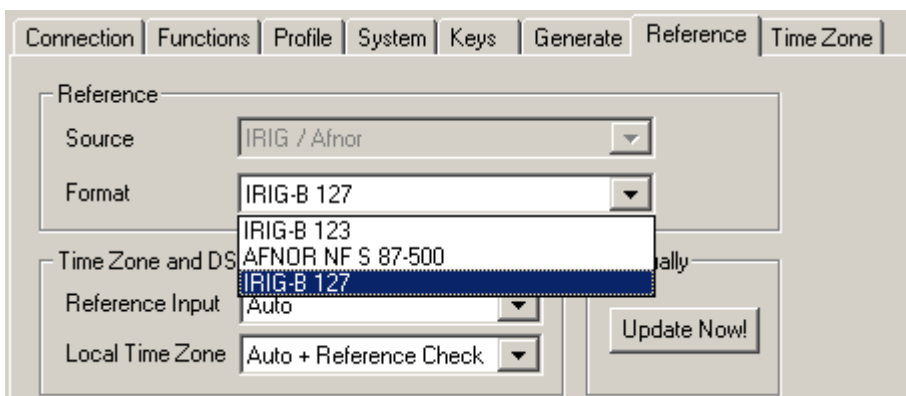

Decoding a date makes the difference:

IRIG-B 123: This format according to IRIG STANDARD 200-04 does not include information about the current year. So the year will be read out of the battery buffered real time clock of the module after power has turned on. It is possible to set the year manually utilizing the configuration tool. Turn of the year will be proceeded automatically. This format conveys "day of year". If the year is known, day and month can be calculated.

IRIG-B 127: This format according to IRIG STANDARD 200-04 includes year information (two digits 00 – 99, meaning 2000 – 2099). Together with the "day of year" information the date can be calculated.

AFNOR NF S 87-500: The format according to NF S 87-500 includes day, month, and year information. So the date can be completely decoded.

3.2 Time Zone of Reference and Local Time Zone

The RUBIDIUM module uses the **UTC** (Universal Time Coordinated) for internal time base. The UTC is calculated: Reference input time \pm offsets as set via configuration. For full functionality this calculated UTC must correspond to the real UTC.

Regarding the IRI-B reference input, two variants are applicable:

1. Time of IRIG-B input corresponds to **UTC** \pm a fixed offset. There is **no Daylight Saving Time switching** (DST).

In this case, please adjust as follows:

Function **Time Zone**

Select offsets at "Reference Input": If there is a fixed time offset to UTC, please select correctly. Otherwise it will not be possible to calculate the internal time base correctly.

Select offsets at "Local Time Zone": The local time zone can be adjusted at will.

Function **Reference**

"Reference Input = **UTC**".

"Local Time Zone = Auto + Reference Check", if local time zone has DST, otherwise "Local Time Zone = UTC + Reference Check".

2. Time of IRIG-B input corresponds to a local time zone **with Daylight Saving Time switching** (DST).

In this case, full functionality is given only if the **local time zone of the output corresponds to the local time zone of the reference input**.

Please adjust as follows:

Function **Time Zone**

Select offsets at "Reference Input": Set **all offsets to 00!**

Select offsets at "Local Time Zone": Any local time zone can be adjusted, but it has to correspond to the time zone of the reference input.

Function **Reference**

"Reference Input = **AUTO**".

"Local Time Zone = Auto + Reference Check".

3.3 IRIG Telegram

At the **Link** page of a configuration tool, an **IRIG** telegram can be enabled.

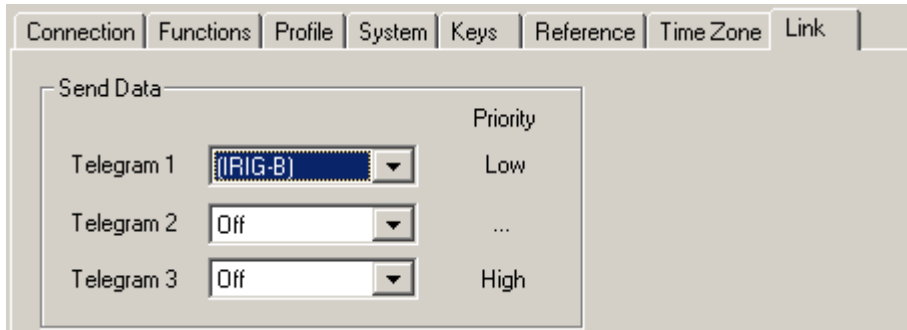

If enabled, the RUBIDIUM module sends IRIG data in a 10 ms interval via the TC_link interface of the RUBIDIUM chassis. Data of the IRIG-B reader will be sent, and the transmission will stop if IRIG-B input fails.

RUBIDIUM video modules, as there are AV/DV/HV/XV or AT/DT/HT/XT modules, are able to decode such a telegram and to visibly insert the data onto a video monitor.

These modules have to receive the following set-up at the **Insert** page:

"Source = IRIG-B"

"Format = IRIG-B"

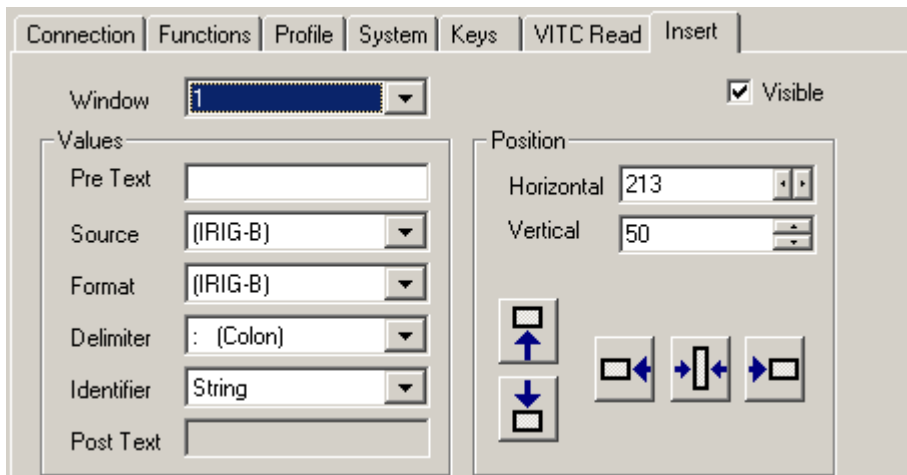

Data will be displayed in the following format:

208 : 10 : 59 : 28 : 96

Day of
Year

HH:MM:SS:1/100

3.4 Status LEDs

The RUB1 version offers four LEDs (named OPER, SIGNAL, SET, and ERROR) which can get a function independently from each other. The following features are suitable for indicating a status of the IRIG-B input signal. Programming of the LEDs is done utilizing the **Keys** page of a configuration tool.

Name (in a drop-down list)	Functional description
IRIG-B Lock	Input signal status. On: IRIG-B with valid data. Data of consecutive IRIG frames are consistent, for example there is no discontinuity of any time information. Slowly flashing: IRIG-B with valid data. The check of consistent data is still in progress or the check fails. Off: No IRIG-B with valid data. Either the signal has failed completely, or the cable has been disconnected, or the signal contains invalid data.
Gen Sync Status	The real-time output signals are frequency and phase locked to the connected IRIG-B signal. This function indicates the status of synchronization. On: Locked. Slowly flashing: Fine trim procedure. Fast flashing: Synchronization is lost.