

Timer Control Unit

# TCUE

Operational Units for Alpermann+Velte's MTDoE System





## CONTENTS

<b>A1</b>	<b>REVISION HISTORY</b>
<b>A2</b>	<b>COPYRIGHT</b>
<b>A3</b>	<b>WARRANTY</b>
<b>A4</b>	<b>UNPACKING/SHIPPING/REPACKAGING INFORMATION</b>
<b>A5</b>	<b>SAFETY INSTRUCTIONS</b>
<b>A6</b>	<b>CERTIFICATIONS &amp; COMPLIANCES</b>

<b>SHORT DESCRIPTION: THE FIRST STEPS</b>	<b>1</b>
Preparation	1
Installation and Set-Up	1
Basic Functions of TCUE within an MTDoe System	4
<b>FUNCTIONAL DESCRIPTION</b>	<b>5</b>
INTRODUCTION	5
POWER SUPPLY	6
START-UP SEQUENCE	7
OPERATING MODES	8
Overview	8
The Keyboard	8
The Displays	9
The Access Rights	9
The Display Modes	10
Overview	10
Local Stop Timer	11
TC: Time Code	11
NTP: Real-Time and Date – Local Time Zone or Reference Time	12
MTD: Real-Time and Date	13
MTD: Timer A - F	14
“Main Timer” Functionality	15
CONFIGURATION	16
The Configuration Program	16
“Profile” Tab: Store and Load a Complete Set-Up	17
“System” Tab: View and Change System Parameters	18
“Source” Tab: Select the Signal Source	19
“Ethernet” Tab: IP Addresses ...	20
“Keyboard” Tab: Function Keys, Access Rights, Beeper	22
“Display” Tab: Display Mode, Brightness, ...	24
“Timer Names” Tab: Customize the OLED Text Display	26
“Real-Time” Tab: Set-Up of the NTP Real-Time Parameters	27
“GPI” Tab: Programming GPI Inputs and Outputs	28
PROGRAMMING FUNCTION KEYS AND GPI INPUTS	30
FIRMWARE UPDATE	34
<b>TECHNICAL DATA</b>	<b>35</b>
CONNECTIONS AT THE REAR	35
SPECIFICATIONS	36

# Operating Manual TCUE

---

MECHANICAL	37
Desktop Housing	37
Module in a 19" 3 RU Housing	37
Special Table Top Mounting	37
19" 1 RU Version: TCU H1	38
TCU-EP AND UD-EP: POWER ADAPTERS	39
Description and Technical Data	39
Safety Precautions	40

## A1 Revision History

No.	Date	Subject
0.x		Preliminary documents, changes without notice.
1.0	March 25, 2010	First released document.
2.0	February 15, 2011	Revised.
2.1	October 14, 2011	- Remark to the lenses of the keys at chapter "Table of Functions to Program Keys and GPIs". - Rear and connectors of TCUE H1 changed.
3.0	February 28, 2012	Completely revised.

## A2 Copyright

Copyright © Alpermann+Velte Electronic Engineering GmbH 2002. All rights reserved. No part of this publication may be reproduced, translated into another language, stored in a retrieval system, or transmitted, in any form or by any means, electronic, mechanical, photocopying, recording, or otherwise without the prior written consent of Alpermann+Velte Electronic Engineering GmbH.

Printed in Germany.

Technical changes are reserved.

All brand and product names mentioned herein are used for identification purposes only, and are trademarks or registered trademarks of their respective holders.

Information in this publication replaces all previously published information. Alpermann+Velte Electronic Engineering GmbH assumes no responsibility for errors or omissions. Neither is any liability assumed for damages resulting from the use of the information contained herein.

For further information please contact your local dealer or:

### **Alpermann+Velte**

Electronic Engineering GmbH

Otto-Hahn-Str. 42

D-42369 Wuppertal

Phone: +49 - 202 - 244 111 0

Fax: +49 - 202 - 244 111 5

E-Mail: [info@alpermann-velte.com](mailto:info@alpermann-velte.com)

Internet: <http://www.alpermann-velte.com>

## **A3 Warranty**

Alpermann+Velte warrants that their products will be free from defects in materials and workmanship for a period of two years from the date of shipment. If this product proves defective during the warranty period, Alpermann+Velte, at its option, will repair or replace the defective product without charge, provided this product are returned to Alpermann+Velte freight pre-paid.

In order to obtain service under this warranty, Customer must notify Alpermann+Velte of the defect before expiration of the warranty period and make suitable arrangements for the performance of service. Customer shall be responsible for packaging and shipping the defective product to Alpermann+Velte, please notice the Shipping Information given below.

This warranty shall not apply to any defect, failure or damage caused by abuse, misuse, improper use, negligence, accident, modification, alteration, or improper or inadequate maintenance and care.

This warranty is given by Alpermann+Velte with respect to this product in lieu of any other warranties, express or implied. Alpermann+Velte and its vendors disclaim any implied warranties of merchantability or fitness for a particular purpose. Alpermann+Velte's responsibility to repair or replace defective products is the sole and exclusive remedy provided to the customer for breach of this warranty. Alpermann+Velte and its vendors will not be liable for any indirect, special, incidental, or consequential damages irrespective of whether Alpermann+Velte or the vendor has advance notice of the possibility of such damages.

## A4 Unpacking/Shipping/Repackaging Information

This product has been carefully inspected, tested and calibrated before shipment to ensure years of stable and trouble-free service.

The shipping carton and pads provide protection for the product during transit. Retain the shipping cartons in case subsequent shipment becomes necessary.

Carefully unpack the product from its transit material and carefully check the product for signs of damage. In the event that the product has been damaged during transit, contact the carrier and your Alpermann+Velte dealer.

Please confirm that all items listed on the packing list have been received. Check the items against your original order to ensure that you have received the correct parts. If any item is missing, please contact your Alpermann+Velte dealer.

Ensure that all packaging material is removed from the product and its associated components before installing the unit.

Products returned to Alpermann+Velte for servicing or repair should have a tag attached showing:

- Name and complete address of the owner and the name of the person that can be contacted.
- Unit's serial number and a description of the service required or failure detected.

Products returned should be shipped prepaid in the original packaging material if possible. If the original packaging is not available or is unfit for use, supply an adequate packaging which should meet the following criteria:

- Packaging must be able to withstand the product weight.
- Product must be held rigid within the packaging.
- Allow at least two inches of space between the product and the container.
- The corners of the product must be protected.
- Seal the carton with shipping tape or an industrial stapler.

If the product is still within the warranty period, the product will be returned by prepaid shipment after servicing.

## A5 Safety Instructions

The general safety information in this part is for both operating and service personnel. Alpermann+Velte products are only to be used as directed. Specific warnings and cautions will be found throughout the manual where they apply.

Review the following safety instructions to avoid injury and prevent damage to this product or any products connected to it.

- Read these instructions.
- Keep these instructions.
- Heed all warnings.
- Follow all instructions.

### Safety Terms and Symbols

Terms and Symbols in this manual:



**CAUTION:** Caution statements identify conditions or practices that could result in damage to this product or other property.

Terms and Symbols which may be found on the product:



**ATTENTION:** Refer to the manual.



Observe precautions for handling electrostatic-sensitive devices.



Signal Ground.

### Product Damage Precautions

#### PREVENT OVERHEATING



To prevent product overheating, position the unit only where sufficient air circulation can be maintained. Good air circulation is essential to prevent internal heat build-up, do not block any ventilation openings. Do not expose the unit to direct sun light or any other strong lights. Keep the unit away from heat sources.

#### PROVIDE PROPER ENVIRONMENT



Dust, humidity, shocks and strong electromagnetic fields must be avoided. Do not expose this apparatus to dripping or splashing water. Ensure that no objects filled with liquid are placed on the apparatus.

## OBSERVE EMC REGULATIONS



The EMC regulations are observed only under the following condition:

Use high quality shielded cables at data inputs and outputs.

## SUSPECTED FAILURES



Whenever it is likely that safe operation is impaired, the apparatus must be made inoperative and secured against unintended operation. The appropriate service authority must then be informed. Do not operate with suspected failures. Servicing is required when the apparatus has been damaged in any way, such as power-supply is damaged, liquid has been spilled or objects have fallen into the apparatus, the apparatus has been exposed to rain or moisture, does not operate normally, or has been dropped.

## PREVENTIVE MAINTENANCE: CLEANING



Qualified Service Personnel Only: The apparatus should be cleaned often enough to prevent dust or dirt from accumulating. Dust accumulating in the apparatus acts as an insulating blanket, preventing proper cooling, and possibly causing overheating and component breakdown. Under high humidity conditions, accumulated dust can also provide an electrical conduction path. Remove accumulated dust with a soft cloth or small paint brush. Remove hardened dirt with a soft cloth, dampened in a mild detergent and water solution. Do not use polish or abrasive cleaners or any other chemical cleaning agents.

## PREVENTIVE MAINTENANCE: VISUAL INSPECTION



Qualified Service Personnel Only: Visually inspect the apparatus for signs of damage, scorched components, and loose or disconnected pin connectors. If you discover heat damaged parts, try to determine the cause of the overheating before replacing the damaged parts; otherwise, the damage may repeat.

## ATTENTION:



Observe precautions for handling electrostatic-sensitive devices. See "Electro Static Discharge (ESD) Precautions" below for details.

## Electro Static Discharge (ESD) Precautions



All semiconductor devices are sensitive to ESD. To prevent any damage or degradation on components of the product caused by ESD, observe these precautions when directed to do so (installing, removing sensitive components):

1. Use a Ground Strap. Wear a grounded anti-static wrist or heel strap to discharge the static voltage from your body.
2. Use a Safe Work Area. Avoid handling components in areas that have a floor or work surface covering capable of generating a static charge. Also nothing capable of generating or holding a static charge should be allowed in the work area.
3. Handle ESD sensitive components carefully. Do not slide components over any surface. Do not touch exposed connector pins. Pick-up components by the body, never by the leads.
4. Transport and store sensitive components or assemblies in a static-protected bag or container.

## A6 Certifications & Compliances

### CE-Declaration:

We,

#### **Alpermann+Velte**

Electronic Engineering GmbH

Otto-Hahn-Str. 42

D-42103 Wuppertal

herewith declare under our sole responsibility that the

#### **TCUE / TCUE H1**

meets the intent of the following directives, standards and specifications:

89/336/EEC Electromagnetic Compatibility

EN 50081-1 Emissions

- EN 55022
- EN 55103-1

EN 50082-1 Immunity

- EN 55024
- EN 55103-2

## Short Description: The First Steps

### Preparation

The following description refers to installation (= integration into an MTDoe system) and set-up of a TCUE device.

Application: Display and control of Timer A (= DOWN) + Timer B (= remaining time).  
Display of local real-time.

Apart from TCUE you need the following accessories:

- MTDoe central unit (RUB GT or GL + RUB IE with option M), UD displays of type "E".
- Ethernet switch + RJ45 Ethernet patch cable.
- Computer with USB and Ethernet interfaces.
- Product CD, included.
- Maybe a standard USB cable: A – B type.

The computer should have been connected to your local network. Connect TCUE via RJ45 patch cable to an Ethernet switch. Switch on all units.

### Installation and Set-Up

S1 Start **UD SC Config.exe** program from CD. At "Filter", "Group = <all>" should have been selected. TCUE should appear on the list:

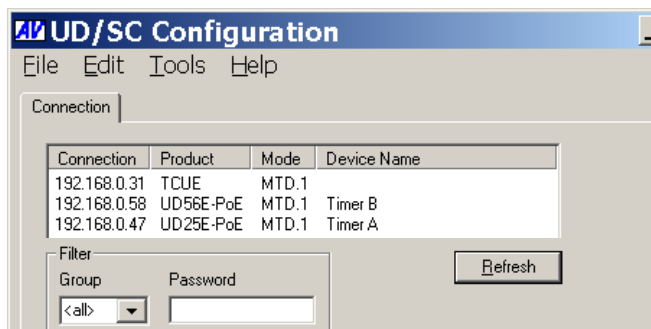

If TCUE does not appear on the list, proceed as follows:

S1a Connect TCUE via USB to the computer. Maybe a driver has to be installed. This driver is part of Windows, it can be found automatically.

S1b Execute **UD SC Config.exe** anew.

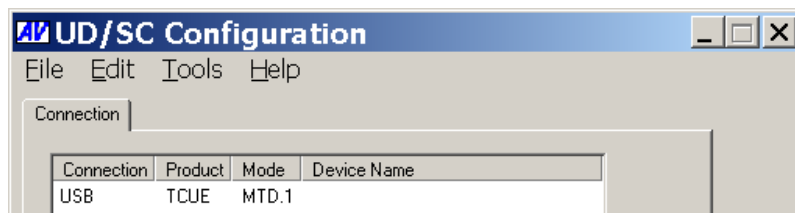

S1c Start the set-up with double-clicking on TCUE.

S1d At **Ethernet** tab:

Click on button **Change ...**, then a new window appears, there click on **Use DHCP**. Make a restart of TCUE and start again at S1.

# Operating Manual TCUE

S2 If there are any other devices on this list, please take notice of the number shown after the name at the "Mode" column (= group number).

S3 Start the set-up with double-clicking on TCUE.

S4 At **System** tab: Give TCUE a significant name.

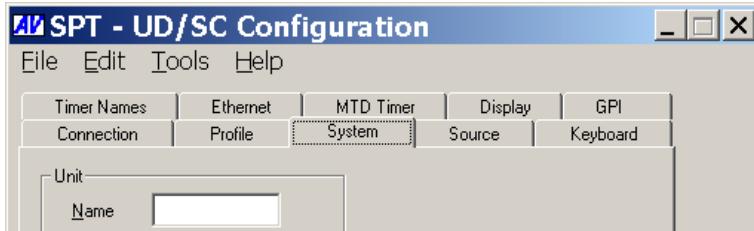

S5 At **Source** tab: Click on "MTD".

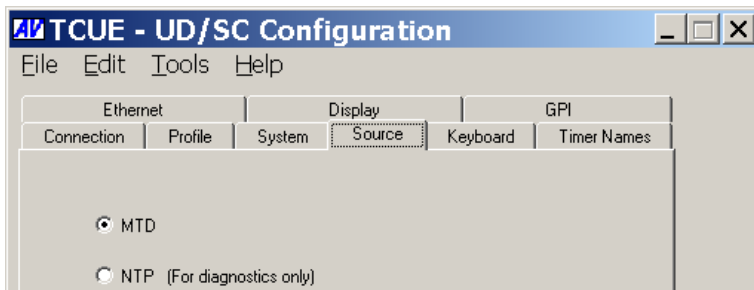

S6 At **Ethernet** tab:

- **Automatic MTD Master IP Address:** Verify, that this checkbox is checked, and that "MTD Master IP Address" shows any IP address which is valid for your network.
- **Group:** Choose a group number identical to the number shown for other devices – as explained at item S2. If there are no other devices, choose "1".

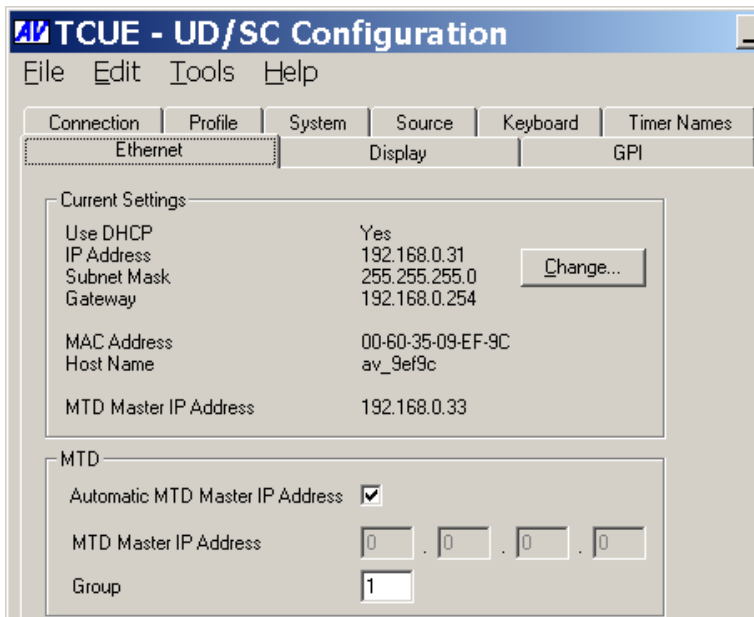

- S7 At **Display** tab: Select "Mode = Real-Time".  
This selection determines the display mode after switching on TCUE, in this case the local real-time will be displayed.

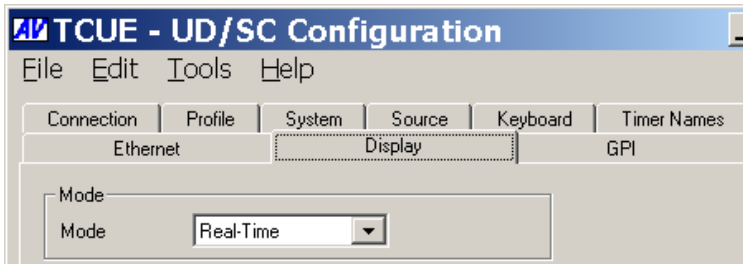

- S9 At **Keyboard** tab:

- At **Buttons**: Programming function keys. In order to control stop timers, assign "Down" to the first and "Diff Time" to the second function key, for example (see next chapter). Assign "No Operation" to keys which are not used.
- At **Access Rights**: This set-up enables you to reduce the functionality of the unit, so that you just work with the functions which are really required for your application. If you just want to control Timer A and Timer B, and display local real-time, click "On" at *Timer A* and *Timer B*, click "Display" at *Time*, and "Off" everywhere else.

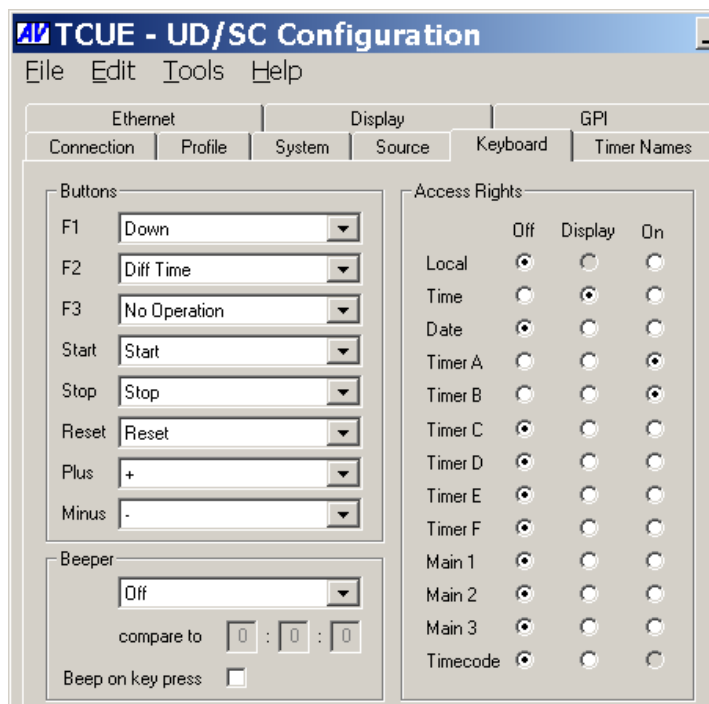

- S10 Installation and basic set-up of TCUE is now completed. Click button **Disconnect**.



The OLED display at TCUE now shows:

## Basic Functions of TCUE within an MTDoe System

Switch TCUE off and on again. After an initialization process, TCUE displays the local real-time.

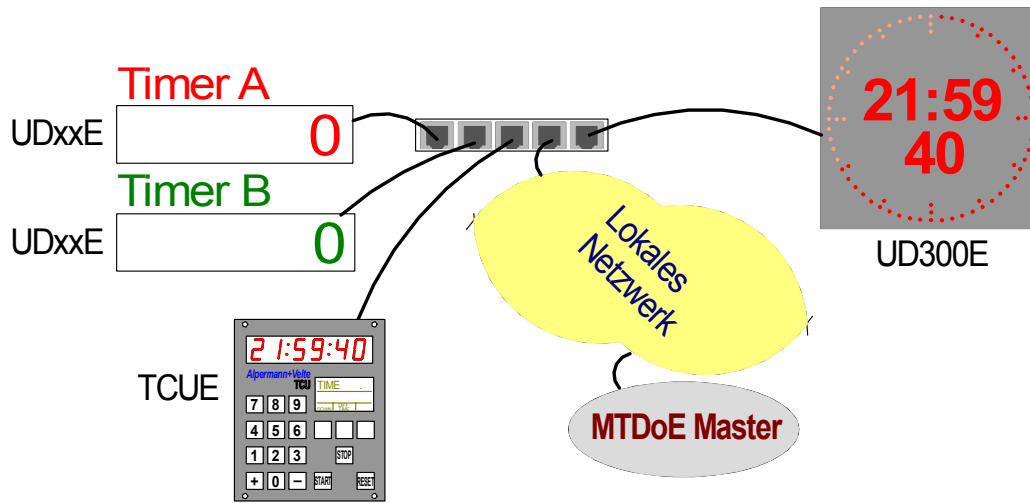

Press key “+” or “-” to switch between those operating modes which are enabled at the “Access Rights” set-up:

- TIME = display of local real-time, no operating;
- TIMER A = stop timer A, e.g. a down-counting timer (DOWN);
- TIMER B = stop timer B, e.g. showing a remaining time.

The following keys at TCUE are provided to control the stop timer:

Press key “+” to switch to **TIMER A**.

0 – 9 Enter a preset value.

Function key DOWN Accept preset value and set stop timer to mode DOWN. Now, the preset value is indicated at all UD displays which show *Timer A*.

START/STOP/RESET Timer starts, timer stops, or timer resets to zero.

- Counter automatically counts upwards if START is pressed at preset = 0.
- Counter automatically counts downwards if START is pressed at preset > 0.

Press key “+” to switch to **TIMER B**.

0 – 9 Enter an event time, e.g. the end of a TV program.

Function key DIFF TIME Accept event value and set stop timer to mode DIFF TIME. Now, the time difference of event time against local real-time will be calculated; this results in a down-counting time (remaining time). This time difference is shown at all UD displays which have display mode set to *Timer B*.

## Functional Description

### Introduction

Alpermann+Velte has developed a system called the Multiple Time Display (MTD) system. An MTD system consists of a central generator unit, control units, digital displays and/or studio clocks. The central MTD generator (RUB GT or RUB GL module) is the time & date reference and manages stop timers.

The **MTDoE** system utilizes the Ethernet to transport the MTD data as well as to communicate between control units and central generator. The central generator transmits the MTD data to the **RUB IE** (with **option M**) Ethernet module via the internal *TC\_link* interface of the RUBIDIUM system, the RUB IE module then opens the gates to the local Ethernet.

The MTD data of the central generator include six independent programmable timers (stop timers, time zones), real-time, date and status data.

Displays, studio clocks and control units read these data and communicate via Ethernet. The Alpermann+Velte devices have to be of type "E" to work within the MTDoE system.

Alpermann+Velte's MTDoE devices have the property to perform an auto-installation within an Ethernet network, i.e. the units find them selves, assign them selves to a group and can be listed, named and configured centrally.

Please refer to "**The MTD System – Installation and Operation Manual**" to read about installation and basic set-up of a TCUE in an MTDoE system.

TCUE is a control unit with a numerical LED display, an OLED information display and a backlit keypad:

- The LED display has 15mm digit height 7-segmented LEDs in a red colour. It simply displays a time in a HH:MM:SS format.
- TCUE H1 can have a second 7-segmented LED display installed. It can be used to display another time, e.g. the first display shows a timer and the second display the local time. Please order TCU DR for a second red display, TCU DG for a green one and TCU DY for a yellow one.
- The colour of the OLED display (Organic Light Emitting Diode) is yellow. It displays the status information.
- The keypad has 18 illuminated keys, 15 keys have an inscription. All keys except the numeric keys 0 – 9 can receive a programmable function. The three keys without inscription are the special function keys, where the current selected function is indicated directly above on the OLED display.



## Power Supply

TCUE receives power either via an external DC power supply or via "Power over Ethernet" (PoE).

### TCU-EP: External Power Supply for TCUE

### UD-EP: External Power Supply for TCUE H1

**TCU-EP** (order number 14100510) and **UD-EP** (order number 14085020) are 24VDC/20W external AC/DC adapters. They are not part of the delivery.

TCU-EP has a (115 cm / 45.3 in) DC output cable with a DSUB9 female connector suitable to connect to the DC connector at TCUE.

UD-EP has a (115 cm / 45.3 in) DC output cable with a 2-pole jack suitable to connect to the DC terminal connector at TCUE H1.

Refer to chapter "TCU-EP and UD-EP: Power Adapters" for detailed technical data.

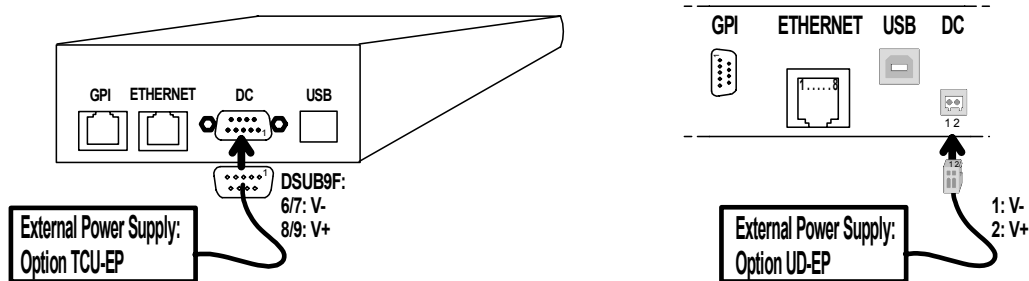

### PoE: "Power over Ethernet"

Power over Ethernet or PoE technology describes a system to pass electrical power, along with data, on Ethernet cabling.

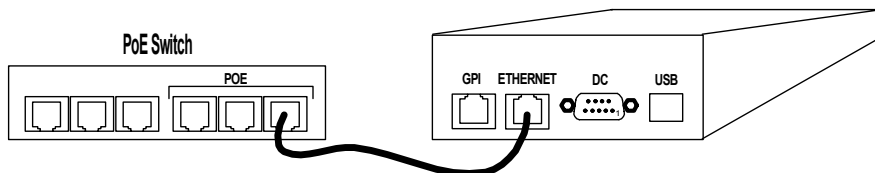

### Pi: "Power Injector"

**Pi** (order number 14085015) is an external AC/DC adapter. It is not part of the delivery.

In the case your network devices cannot supply PoE, using this PoE injector keeps the advantage to have only one cable connected to your TCUE or TCUE H1.

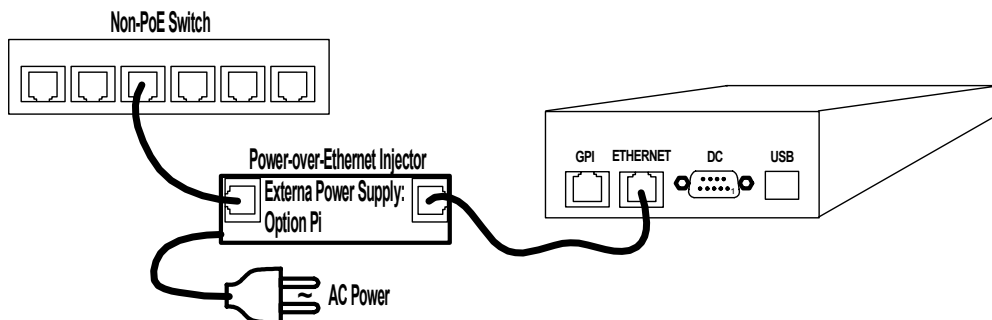

## Start-Up Sequence

The OLED display indicates step by step:



- the firmware revision number,
- and then installed options – if any Option,
- and then the selected source,
- and then it switches to normal operating mode.

2.4
TCUE

SRC: MTD	SRC: NTP
MTD CLIEN	NTP CLIEN

In the beginning, all of the LEDs and lamps will light up shortly.

The red LED display indicates status information step by step:

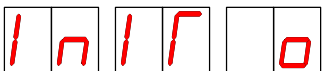
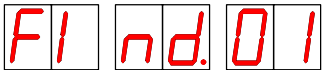
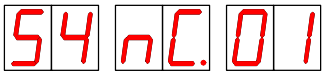
	<p>Current display mode at the last two digits of the LED display:</p> <table border="1"> <thead> <tr> <th>Digits</th> <th>Mode</th> <th>Source</th> </tr> </thead> <tbody> <tr><td>□ L</td><td>Local</td><td>MTD</td></tr> <tr><td>r Γ</td><td>Real-Time</td><td>MTD</td></tr> <tr><td>r d</td><td>Date</td><td>MTD</td></tr> <tr><td>Γ A</td><td>Timer A</td><td>MTD</td></tr> <tr><td>Γ B</td><td>Timer B</td><td>MTD</td></tr> <tr><td>Γ C</td><td>Timer C</td><td>MTD</td></tr> <tr><td>Γ d</td><td>Timer D</td><td>MTD</td></tr> <tr><td>Γ E</td><td>Timer E</td><td>MTD</td></tr> <tr><td>Γ F</td><td>Timer F</td><td>MTD</td></tr> <tr><td>□ 1</td><td>Main 1</td><td>MTD</td></tr> <tr><td>□ 2</td><td>Main 2</td><td>MTD</td></tr> <tr><td>□ 3</td><td>Main 3</td><td>MTD</td></tr> <tr><td>Γ L</td><td>Time Code</td><td>MTD</td></tr> <tr><td>n Γ</td><td>NTP Time</td><td>NTP</td></tr> <tr><td>n d</td><td>NTP Date</td><td>NTP</td></tr> </tbody> </table>	Digits	Mode	Source	□ L	Local	MTD	r Γ	Real-Time	MTD	r d	Date	MTD	Γ A	Timer A	MTD	Γ B	Timer B	MTD	Γ C	Timer C	MTD	Γ d	Timer D	MTD	Γ E	Timer E	MTD	Γ F	Timer F	MTD	□ 1	Main 1	MTD	□ 2	Main 2	MTD	□ 3	Main 3	MTD	Γ L	Time Code	MTD	n Γ	NTP Time	NTP	n d	NTP Date	NTP
Digits	Mode	Source																																															
□ L	Local	MTD																																															
r Γ	Real-Time	MTD																																															
r d	Date	MTD																																															
Γ A	Timer A	MTD																																															
Γ B	Timer B	MTD																																															
Γ C	Timer C	MTD																																															
Γ d	Timer D	MTD																																															
Γ E	Timer E	MTD																																															
Γ F	Timer F	MTD																																															
□ 1	Main 1	MTD																																															
□ 2	Main 2	MTD																																															
□ 3	Main 3	MTD																																															
Γ L	Time Code	MTD																																															
n Γ	NTP Time	NTP																																															
n d	NTP Date	NTP																																															
 	<p>“Init” indicates that the Ethernet initialization is still in progress. After success “Init o” shortly will be displayed, then or after one minute at the latest the device switches to normal operating mode.</p>																																																
	<p>In case “source = MTD”: The device tries to find the RUB IE module responsible for the indicated MTD group number.</p>																																																
	<p>In case “source = MTD”: The MTD<sub>oE</sub> Master has been found, now the device synchronizes its internal clock with NTP commands.</p>																																																

## Operating Modes

### Overview

TCUE is a timer display and control unit. A timer can be a local real-time or date, a stop timer, a remaining time, or more.

TCUE receives data via Ethernet. There are two different methods corresponding to two different sources TCUE can use to decode and display data. Selection of this source will be done by **configuration** of the unit (chapter "Source" Tab: Select the Signal Source).

- Source = **MTD**: TCUE is able to decode and display all the timers of the MTD data. The MTD data include six independent programmable timers, real-time, date, and a time of a time code. Each timer can show a stop timer, a remaining time, a time difference, a time of a time zone etc. TCUE can control these timers, e.g. by start/stop/reset commands, or by setting a start value, etc.
- Source = **NTP** (for service purposes only): TCUE receives and displays a time & date. The received reference time can get a programmable offset. It is possible to enable a Daylight Saving Time handling. This programming is done by configuration of the unit.
- TCUE can be set to a local timer mode, thus being independent from any external interface. TCUE can control this timer by start/stop/reset commands, by setting a start value, etc.

TCUE offers a numerical keypad, programmable function keys, and two displays.

### The Keyboard

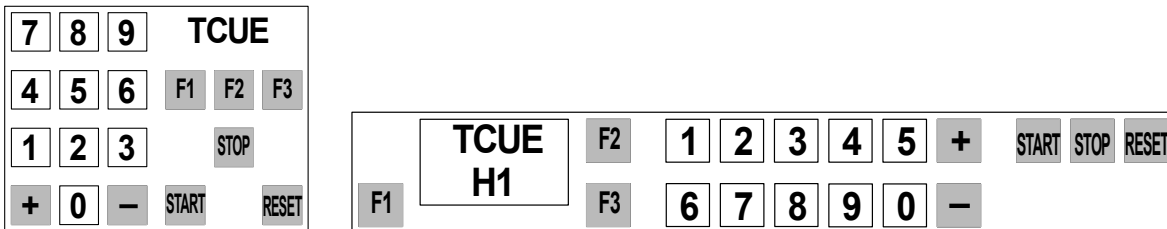

- 0 – 9 keys to enter numerical values; these keys are not programmable.
- The + and – keys are preferably used to switch to the next display mode, but they could also receive a user defined function.
- The START/STOP/RESET keys are preferably used for a stop timer operation, but they could also receive a user defined function.
- The F1 – F3 keys receive a user defined function, e.g. UP or DOWN to select a stop timer mode, or A, B, to switch to a specific display mode. The backlit lamp in the key will light up if the programmed function is currently activated. A text on the OLED display just near the key describes the programmed function.
- Programming of the keys is done by **configuration** of the unit and will be stored at a non-volatile memory of the TCUE (chapter "Keyboard" Tab: Function Keys, Access Rights, Beeper).

## The Displays



During normal operating mode the red LED display (at TCUE H1 the LED display to the right (= 1<sup>st</sup> display) shows the time of the selected timer or, if any date mode has been selected, a date. During an input with the numerical keypad the display switches to show the entries.

The optional available 2<sup>nd</sup> display of the TCUE H1 shows no entries, it shows the time of the selected timer or, if any date mode has been selected, a date.

The OLED display shows the following information:

### TCUE

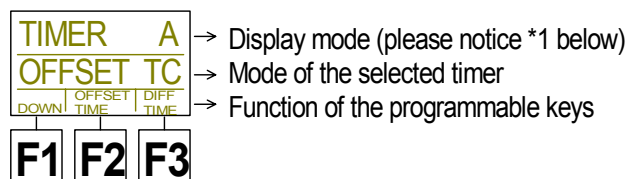

### TCUE H1

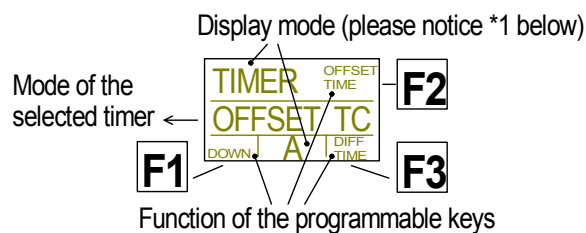

**\*1** Special cases: A leading “\*” indicates that this timer can be remote controlled by an automation system. Example: “\*A”.

A leading “.” indicates that operation on this timer has been disabled (access rights has been set to “display only”). Example: “.A”.

## The Access Rights

According to application it is recommended not to enable the control to every display mode. For example it is possible to disable the control of selected stop timers or to refuse setting the real time. Even displaying the time of specific timers can be disabled, thus limiting TCUE’s functionality to those timers actually used in a given application. This keeps the operation on the timer system easy.

This installation is done by the *Access Rights* feature. A display mode can be switched to:

- On** = displaying and operating possible;
- Display** = displaying possible but no operating;
- Off** = neither displaying nor operating possible.

Programming the *Access Rights* is done by **configuration** and will be stored at a non-volatile memory of TCUE (chapter ““Keyboard” Tab: Function Keys, Access Rights, Beeper).

## The Display Modes

### Overview

The + and – keys are preferably used to switch to the next display mode. The *Access Rights* feature offers to completely disable a display mode, this mode will then be skipped in case of switching from one mode to the other.

The following display modes are available:

Mode	OLED Text	Source	Description
Local stop timer	LOCAL		No Ethernet connection required
Real-time	TIME NTP	NTP	Real-time received from an NTP Server, $\pm$ Offset
Date	DATE NTP	NTP	Date, received from an NTP Server, $\pm$ Offset
Real-time	TIME	MTD	Display and control of MTD real-time
Date	DATE	MTD	Display and control of MTD date
Timer A	TIMER A	MTD	Display and control of timer A (e.g. stop timer A)
Timer B	TIMER B	MTD	Display and control of timer B (e.g. stop timer B)
Timer C	TIMER C	MTD	Display and control of timer C (e.g. stop timer C)
Timer D	TIMER D	MTD	Display and control of timer D (e.g. stop timer D)
Timer E	TIMER E	MTD	Display and control of timer E (e.g. stop timer E)
Timer F	TIMER F	MTD	Display and control of timer F (e.g. stop timer F)
1 <sup>st</sup> main timer	MAIN-1	MTD	Display and control of 1 <sup>st</sup> "main timer"
2 <sup>nd</sup> main timer	MAIN-2	MTD	Display and control of 2 <sup>nd</sup> "main timer"
3 <sup>rd</sup> main timer	MAIN-3	MTD	Display and control of 3 <sup>rd</sup> "main timer"
Time code	TC	MTD	Displaying the time of the MTD <sub>oE</sub> reference

By **configuration** of the unit it is possible to determine the display mode which TCUE selects after power-on: Chapter "Display" Tab: *Display Mode, Brightness, ...*

## Local Stop Timer

- The time of the local stop timer is displayed at TCUE only. There is no data transfer to any other display ("Source = NTP") or to any MTDoe central unit ("Source = MTD").
- The local stop timer mode is available at *source = MTD* or *source = NTP*.

The following keys and functions are provided to control this timer:

START/STOP/RESET      Keys at TCUE or external keys connected to GPI inputs.

0 – 9                      Enter a preset value.

UP                              Timer counts upwards.

Example: Enter a preset value, press UP key, then START key →  
timer counts upwards starting from the preset value.

DOWN                         Timer counts downwards.

Example: Enter a preset value, press DOWN key, then START key →  
timer counts downwards starting from the preset value.

- Counter automatically counts upwards if START is pressed at preset = 0.
- Counter automatically counts downwards if START is pressed at preset > 0.
- There are more functions available using programmable keys or GPI inputs according to table "Local timer and timer A – F commands" at chapter "Programming Functions Key and GPI Inputs".

## TC: Time Code

- *Source = MTD*: Displays the time of the reference of the MTDoe master.  
If MTDoe master consists of a RUB GT (GL) – RUB IE system, this time corresponds to the time of the generated time code, usually = time of the local time zone.  
If MTDoe master consists of a SPT unit, this time corresponds to UTC.
- There is no operating by keys or GPI inputs provided.

## NTP: Real-Time and Date – Local Time Zone or Reference Time

- *Source = NTP* has to be selected.
- “Real-Time” mode enabled:  
Displaying real-time or date of your local time zone. Local time zone is based on data requested from an NTP server, and is calculated using programmable offsets.
- “Real-Time” mode disabled:  
Displaying reference time and date – without offsets.
- There is no operating by keys or GPI provided.
- Flashing decimal points or colons indicate that synchronization has been lost.

The following set-up can be done:

### Select an NTP Server

Enter the IP address of a primary and – if available – of a secondary NTP server. Please refer to chapter “Ethernet” Tab: IP Addresses ...

### Select time offsets and Daylight Saving Time switching

Set-up of “Real-Time” mode and time offsets and automatic Daylight Saving Time switching is done at two tabs:

**Real-Time** tab (chapter “Real-Time” Tab: Set-Up of the NTP Real-Time Parameters).

**Display** tab (chapter “Display” Tab: Display Mode, Brightness ...).

Set-up at both tabs determines the display of time and date. Programming of two local time zones is provided.

Tab <b>Real-Time</b> : Checkbox <b>Enable Real-Time</b>	Tab <b>Display</b> : Selection box <b>Time Zone</b>	<b>Display</b>
Not checked	X	Time & date of NTP Server = Time & date of reference.
X	Off	Time & date of NTP Server = Time & date of reference.
Checked	Time Zone 1	Time Zone 1: Reference ± offsets according to “Local Time Zone 1” set-up at tab <b>Real-Time</b> .
Checked	Time Zone 2	Time Zone 2: Reference ± offsets according to “Local Time Zone 2” set-up at tab <b>Real-Time</b> .

### Programming the representation of time and date display

**Display** tab:

Mode	Display - Format	Display – Delimiter
<b>NTP Time</b>	24-hour or 12-hour (am/pm)	Colons, decimal points, or none.
<b>NTP Date</b>	DD.MM.YY MM.DD.YY YY.MM.DD.	Colons, decimal points, or none.

## MTD: Real-Time and Date

- Displaying time or date of the real-time decoded out of the MTD data.
- *Source = MTD* has to be selected.

The following set-up can be done utilizing the "Display" tab (chapter "Display" Tab: Display Mode, Brightness ...):

### Choose the delimiter

This set-up determines the separating sign of the LED display:

Auto	Automatically decoded out of the MTD status data.	
Off	No sign:	Example: 23 59 59
.	Decimal Point:	Example: 23.59.59
:	Colon:	Example: 23:59:59

### Set time or date

If enabled by configuration of the *Access Rights* it is possible to set time and date.

**Attention:** Altering time or date will alter the most important parameters of the system. All timers relate on the real-time. A leap in time will lead to a jump in the time code and in the NTP time of the MTD<sub>o</sub>E central unit. All connected units receiving a time via time code from the central MTD generator or via NTP from the MTD<sub>o</sub>E central unit have to handle this leap in time. Therefore it is strongly recommended to set the access rights to "Display" or "Off" in order to avoid unintentional operating.

During normal operating mode the central MTD generator always outputs a correct time. If this is not true the cause of this failure should be found and cleared.

Enter a new value with the numerical keypad, then press START or UP. The entry of a preset value can be cancelled by using the RESET or + or – key.

Maybe the display of the TCUE does not show the corrected time at once, because it may last up to 60 seconds until synchronization has been established.

Altering other parameters of MTD time or date – as there is time in a 12 or 24 hour format – is part of the MTD system's configuration. Please refer to "**The MTD System – Installation and Operation Manual**" to read about installation and basic set-up of the MTD system.

## MTD: Timer A - F

- Displaying the current time of the selected timer, decoded out of the MTD data.
- *Source = MTD* has to be selected.

The following set-up can be done utilizing the "Display" tab (chapter "Display" Tab: Display Mode, Brightness ...):

### Choose the delimiter

This set-up determines the separating sign of the LED display:

Auto	Automatically decoded out of the MTD status data.	
Off	No sign:	Example: 23 59 59
.	Decimal Point:	Example: 23.59.59
:	Colon:	Example: 23:59:59

There are more set-ups provided to change the representation of the time, e.g. switching on or off the leading zeros, displaying 1/10 or frames, and more. You will find the detailed description in "**The MTD System – Installation and Operation Manual**".

The following keys and functions are provided to control a timer:

START/STOP/RESET      Use a TCUE key or an external key connected to a GPI input.

0 – 9                  Enter a preset value or event time.

FUNKTION      There are several functions programmable for a key or GPI:

HOLD	Freeze the time at the display.
START/STOP	Timer = Stop timer: Start/stop alternating.
RESET+START	Timer = Stop timer: Timer starts from 0.
RESET CONT.	Timer = Stop timer: Reset at stop, else Reset+Start.
UP	Timer = Stop timer: UP operating mode.
DOWN	Timer = Stop timer: DOWN operating mode.
DOWN+START	Timer = Stop timer: DOWN, timer starts from 0.
ALL	Control all timers - enabled for operating - simultaneously.
DUE	DOWN/UP/END combination.
DUE NEXT	DOWN/UP/END combination + NEXT.
SET NEXT	Transfer next preset value.
NEXT DUE	DOWN/UP/END combination + preset from SET NEXT.
OFFSET+	Timer = Stop timer: Add a correction value.
OFFSET-	Timer = Stop timer: Subtract a correction value.
OFFSET TIME	Timer = Real-time + offset.
OFFSET TC	Timer = VTR-LTC + offset.
DIFF TIME	Timer = Difference of event time – real-time
DIFF TC	Timer = Difference of event time – VTR-LTC.

You will find the detailed description of the functions in "**The MTD System – Installation and Operation Manual**".

## “Main Timer” Functionality

The “Main Timer” feature enables a remote control of displays within the timer system. There are three main timers provided, therefore three groups of displays can be controlled independently. Within one group all displays show the same time. These groups belong to the same timer system, not to mix up with MTD groups defined at the “Ethernet” tab.

The displays will be set to mode **1st main timer** or **2nd main timer** or **3rd main timer**.

The time of a “Main Timer” can be one of the following eight:

Real-Time, Date, Timer A, Timer B, Timer C, Timer D, Timer E, Timer F.

Now you can select what the “Main Timer” should be. The following functions are provided for a function key or GPI input at TCUE:

MAIN1 = Time	MAIN2 = Time	MAIN3 = Time
MAIN1 = Date	MAIN2 = Date	MAIN3 = Date
MAIN1 = Timer A	MAIN2 = Timer A	MAIN3 = Timer A
MAIN1 = Timer B	MAIN2 = Timer B	MAIN3 = Timer B
MAIN1 = Timer C	MAIN2 = Timer C	MAIN3 = Timer C
MAIN1 = Timer D	MAIN2 = Timer D	MAIN3 = Timer D
MAIN1 = Timer E	MAIN2 = Timer E	MAIN3 = Timer E
MAIN1 = Timer F	MAIN2 = Timer F	MAIN3 = Timer F

These function keys operate independently of the selected display mode.

Additionally, “Main Timer” can be changed utilizing the following keys provided that TCUE actually displays any “Main Timer”. Display mode = MAIN 1 or MAIN 2 or MAIN 3, then the corresponding “Main Timer” changes to:

Key <b>7</b> : Timer D	Key <b>8</b> : Timer E	Key <b>9</b> : Timer F
Key <b>4</b> : Timer A	Key <b>5</b> or <b>START</b> : Timer B	Key <b>6</b> or <b>STOP</b> : Timer C
Key <b>1</b> :	Key <b>2</b> or <b>RESET</b> : Real-Time	Key <b>3</b> : Date

Example of function key application – displays set to **1st main timer**:

- Function key F1 programmed to “MAIN1 = Time”.
- Function key F1 programmed to „MAIN1 = Timer A”.
- Pressing key F1 → Displays show “Time”.
- Pressing key F2 → Displays show “Timer A”.

Example of GPI input application – displays set to **1st main timer**:

- One signal/switch changes between two display modes.
- GPI programming: GPI 1 = “MAIN1 = Time”, “Mode = Active Low”;
- GPI 2 = “MAIN1 = Timer A”, “Mode = Active High”.

Switch closed: Displays show “Time”      Switch opened: Displays show “Timer A”

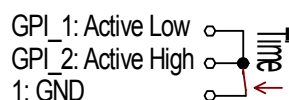

## Configuration

### The Configuration Program

Configuration requires the **UD SC Config.exe** program running on a computer (32 or 64 bit Windows operating system 2000/XP/2003/Vista/2008/7). You can download the latest version of the program from:

[http://www.alpermann-velte.com/serv\\_e/software\\_e/software\\_e.html](http://www.alpermann-velte.com/serv_e/software_e/software_e.html).

Every device of the TCUE series can be configured via a USB interface or via Ethernet. Access via Ethernet can be protected by a password (chapter "System" Tab: View and Change System Parameters). Firmware update is performed by this program as well, but this requires the USB connection (chapter "Firmware Update").

USB connection requires a standard USB cable (A – B type). It is recommended but not needed to have the device connected to an external power supply. If no power supply is connected, the device can be configured as usual, but the device will stay in a shut-off mode, regardless of current set-up. The first time the device is plugged to the PC, Windows will install a driver for it. This driver is part of Windows, you don't need a CD.

After program start a list is given of all devices found:

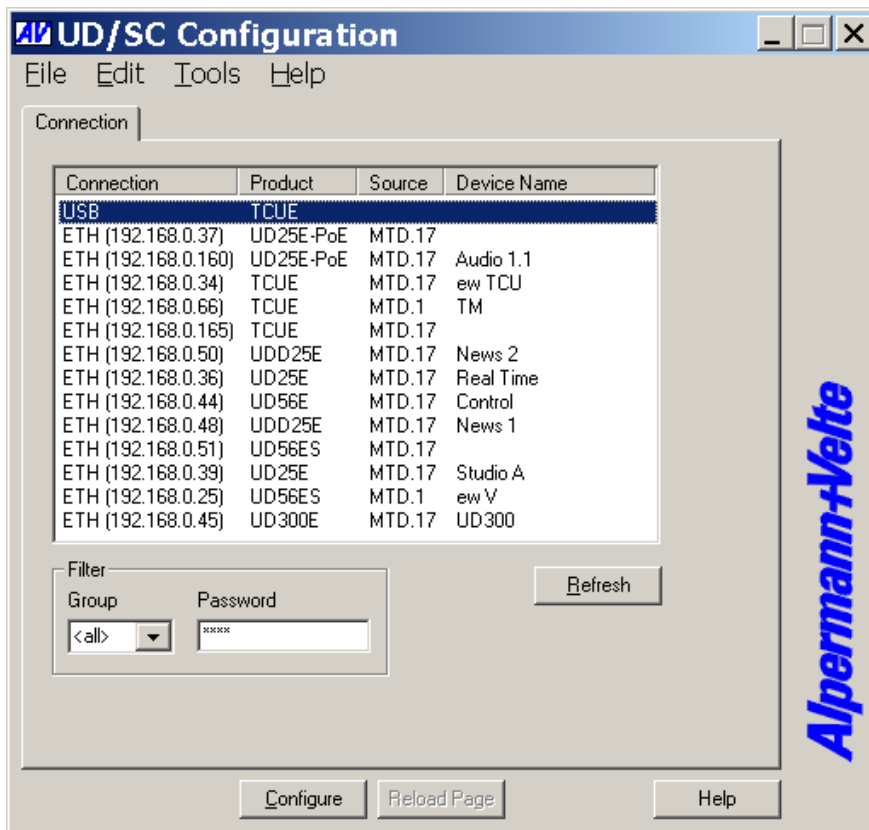

Open the configuration by marking the device on the list and pressing button "Configure", or by a double click on a device in the list. Additional tabs will be shown. On these tabs you can check or change the configuration of the selected device as described in the following chapters.

Please refer to "The MTD System – Installation and Operation Manual" for a detailed description of the general features of this configuration program

## “Profile“ Tab: Store and Load a Complete Set-Up

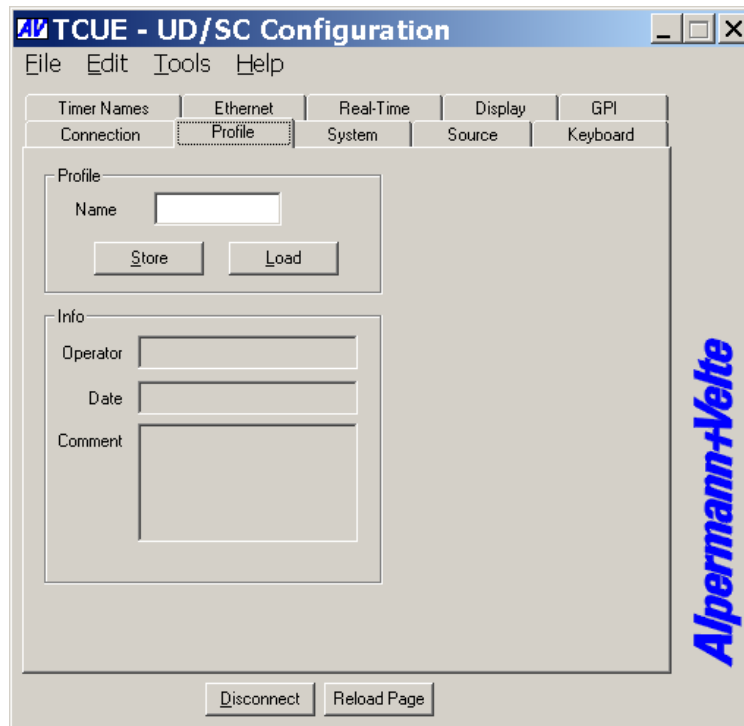

This feature enables to easily change the complete set-up of the unit during normal operation. During installation, the current set-up can be stored as a “profile”. You can enter a name in the “name” entry before storing. Now choose a different set-up and store this as a different profile. Five profiles are available. Programming any function key or GPI inputs with “Load Profile ...” functions enables you to change over from one set-up to the other during normal operation. Please also refer to chapter “Programming Function Keys and GPI Inputs”.

Five different set-ups can be stored into the non-volatile memory of the unit.  
Click **Store**:

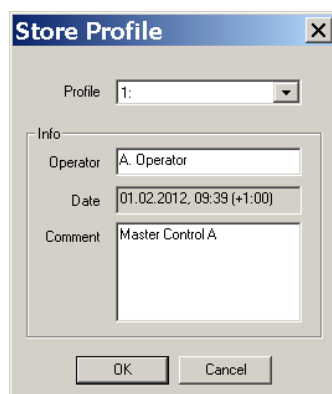

**Profile:** Select 1 – 5.

**Info** Operator: You may enter a text.  
Comment: You may enter a text.

Click **OK** to store the current set-up.

Any set-up stored as a profile can replace the current set-up.  
Click **Load**:

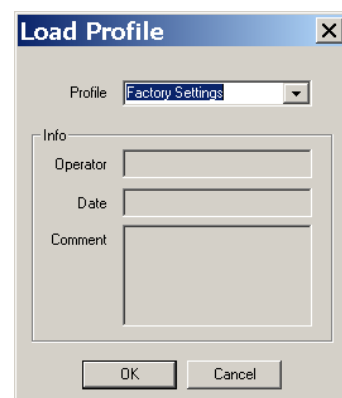

**Profile:** Select “Factory Settings” or 1 – 5.  
“Factory Settings” installs the default set-up.

Click **OK** to replace the current set-up by the selected profile. If no valid set-up has been stored, an error message is given.

## “System“ Tab: View and Change System Parameters

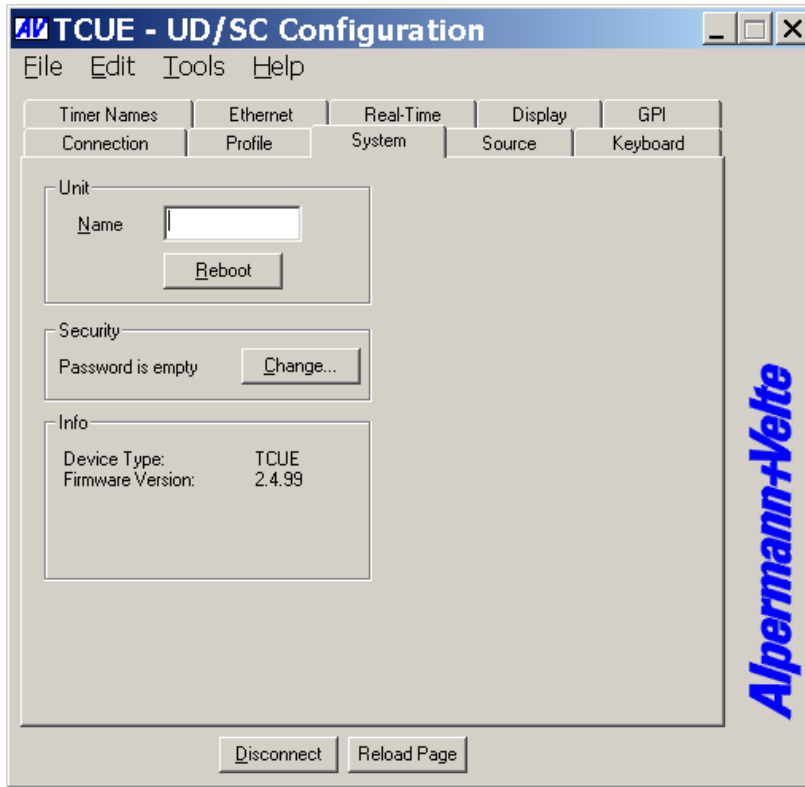

### Unit

Name	Give the device a significant name. This name appears in the list and allows a specific configuration in a comfortable way. Enter a text (10 characters) in the <i>Name</i> field. Complete with <i>Enter</i> or <i>Tab</i> key.
Reboot	Warm boot of the unit.

### Security

It is provided to protect the unit against non permission or unintentional access via Ethernet. Any configuration with a USB connection ignores the password.

With a click on the **Change** button the following entry opens:



Enter the password twice and press the **OK** button.  
Clear an existing password by checking **No Password**.

### Info

Indicates some device status, e.g. the version of the installed firmware.

## “Source“ Tab: Select the Signal Source

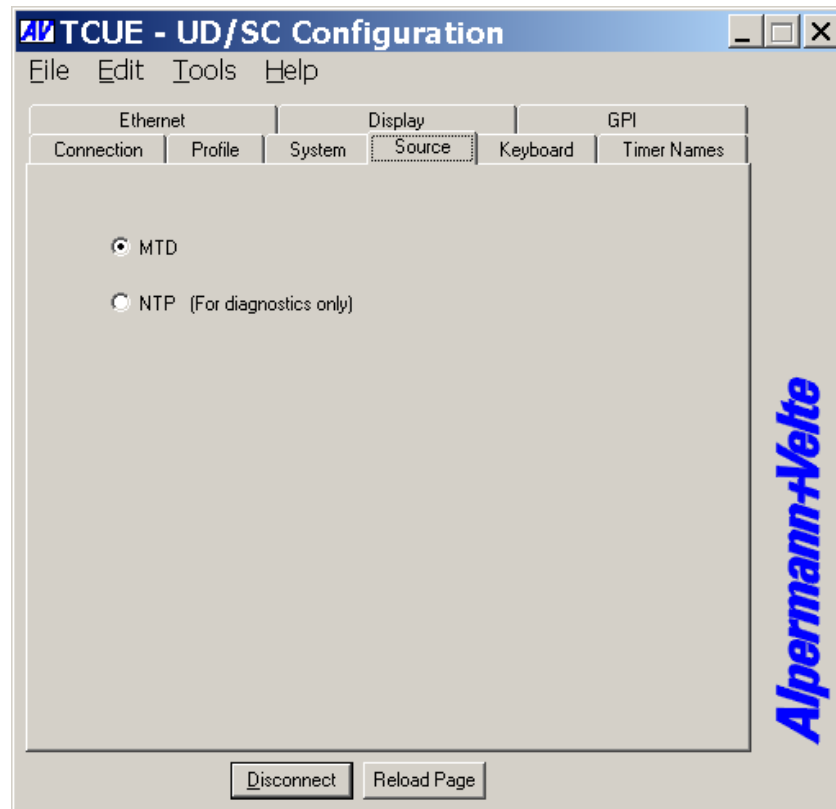

TCUE offers two different *main operating modes*, determined by selecting the signal source.

### MTD

TCUE operates as timer control unit of the MTD<sub>oE</sub> system:

TCUE is able to decode and display data of an MTD<sub>oE</sub> system. These data include six independent programmable timers, real-time, date, and a time of a time code. Each timer can show a stop timer, a remaining time, a time difference, a time of a time zone etc. TCUE can communicate with an MTD<sub>oE</sub> Master and control these timers, e.g. by start/stop/reset commands, or by setting a preset value, etc.

### NTP (for diagnostics only)

TCUE operates as NTP Client, for service purpose only:

TCUE receives and displays a time & date. The received reference time can get a programmable offset. It is possible to enable a Daylight Saving Time handling.

Each *main operating mode* offers to control and display a **local stop timer** - even without an Ethernet connection.

## “Ethernet“ Tab: IP Addresses ...

“Source = MTD”

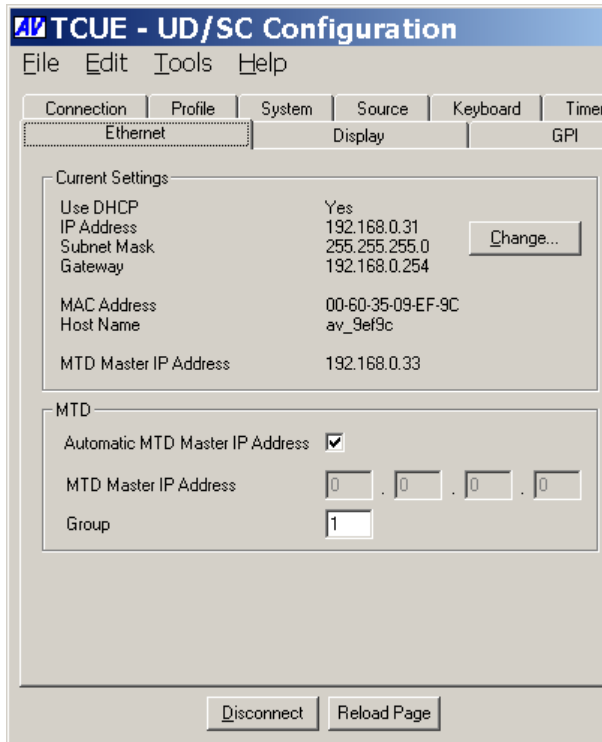

“Source = NTP”

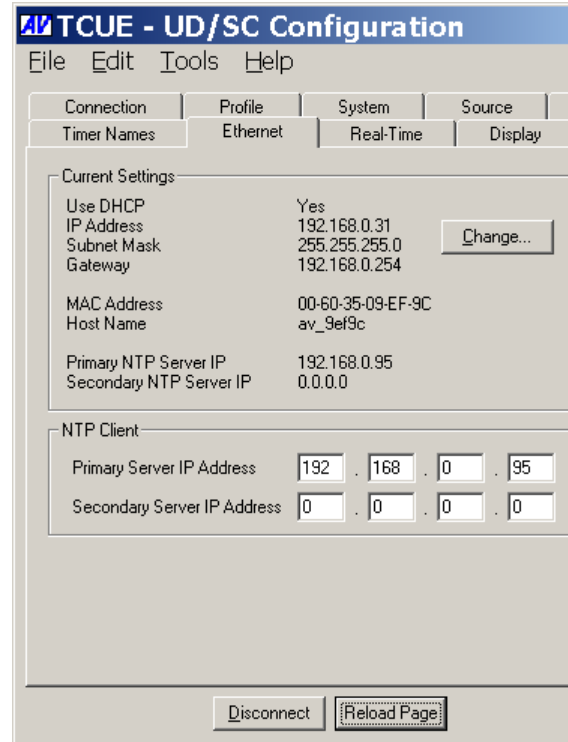

## Current Settings

This box indicates the current network parameters of the device.

A click on **Change...** enables to change parameters:

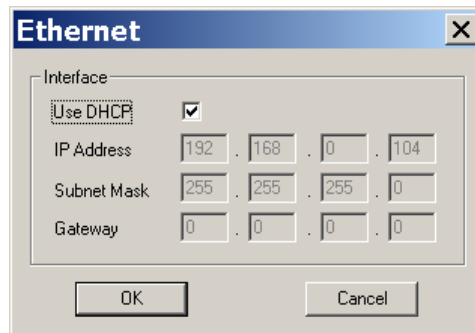

**Use DHCP** If checked, the device will automatically request its IP parameters (IP address, subnet mask, and gateway) from a DHCP server. In this case the “IP Address”, “Subnet Mask”, and “Gateway” boxes have no relevance.

Please let the device restart (power off – on) if you select this mode.

If "Source = MTD" has been selected:

## MTD

<b>Automatic MTD Master IP Address</b>	If checked, the device will automatically find the MTD <sub>oE</sub> central unit responsible for the group number below. In a redundant system (two MTD <sub>oE</sub> central units), an automatic changeover can take place in case one central unit fails.
<b>MTD Master IP Address</b>	If "Automatic Host IP Address" is not checked, the IP address of the MTD <sub>oE</sub> central unit has to be entered manually.
<b>Group</b>	Indicates the MTD <sub>oE</sub> group number. Likewise, you can change this number here.

Click **Reload Page** at the bottom of the tab if the „Current Settings“ box does not show the new parameters.

If "Source = NTP" has been selected:

## NTP Client

Enter the IP addresses which the NTP client of the device uses to request time & date information of an NTP server.	
<b>Primary Server IP Address</b>	Address of the primary (1st) NTP server.
<b>Secondary Server IP Address</b>	Address of a secondary (back-up) NTP Server.

Click **Reload Page** at the bottom of the tab if the „Current Settings“ box does not show a changed address.

## “Keyboard“ Tab: Function Keys, Access Rights, Beeper

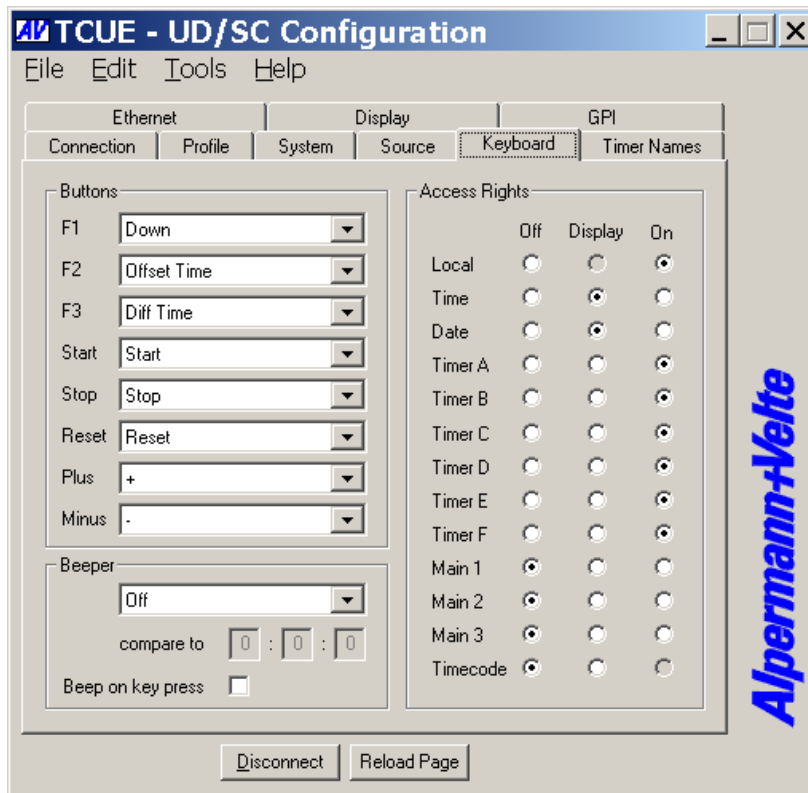

### Buttons

Eight keys can receive a function out of a dropdown list.

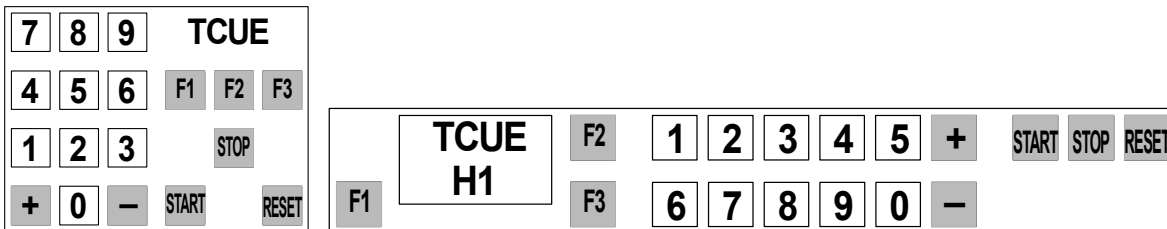

Please refer to chapter “Programming Function Keys and GPI Inputs” for detailed information about available functions.

### Access Rights

Each display mode can receive an **Access Rights** configuration. This set-up enables you to reduce the functionality of the unit, so that you just work with the functions which are really required for your application.

- On This timer can be displayed and controlled.
- Off This timer can neither be displayed nor controlled. This mode will be skipped if the display modes will be switched utilizing the + and – keys.
- Display This timer can be displayed, but not controlled. The OLED display indicates this set-up by a dot leading the number of the timer, e.g.: “.A”.

## Beeper

TCUE can give a short “beep”, if the time of a selected timer or the real-time matches the value at “**compare to**”. Select the timer out of the drop-down list. The drop-down list offers different functions depending on the selection at “Source”. The “Display” function compares the current time shown at the display. All other functions compare the selected timer or the selected time – no matter of the display mode.

Functions – dependent on “Source” selection:

<i>Function</i>	<i>Description</i>	<i>available for “Source”</i>
<b>Display</b> TCUE with 2 displays: Display 1 Display 2	Time comparison with the time currently shown at the display.	MTD NTP
<b>Local</b>	Time comparison with local (internal) stop timer.	MTD NTP
<b>Real-Time</b>	Time comparison with real-time (= time of local time zone).	MTD
<b>Time UTC</b>	Time comparison with NTP reference.	NTP
<b>Time Zone 1</b> <b>Time Zone 2</b>	If real-time operating mode has been selected: Time comparison with the time of the selected time zone.	NTP
<b>Timer A ... F</b>	Time comparison with selected timer A ... F.	MTD
<b>Main 1 ... 3</b>	Time comparison with selected “Main Timer” 1 ... 3.	MTD
<b>Time code</b>	Time comparison with the time shown at display mode “Time code”. Please also refer to chapter “Time Code (TC)”	MTD

**compare to:** Enter hours (0 – 23) : minutes (0 – 59) : seconds (0 – 59).

<b>Beep on key press</b>	If checked, TCUE gives a “beep” each time a key is pressed.
--------------------------	---

## “Display“ Tab: Display Mode, Brightness, ...

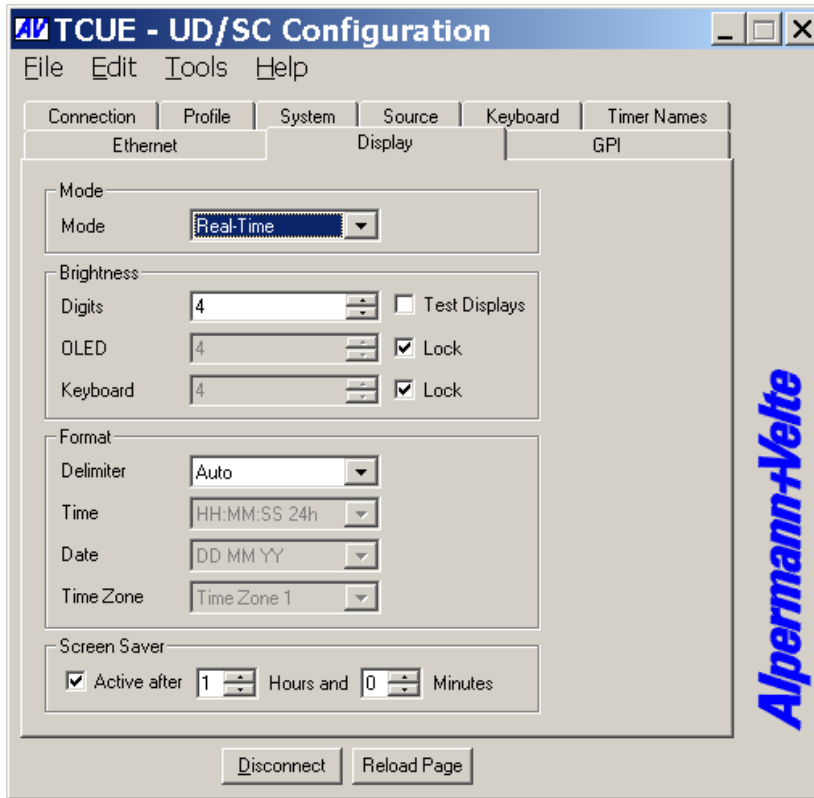

With a TCUE H1 equipped with a second display, the right display (1) and the left display (2) can be set separately, in this case two tabs will be shown.

### Mode

Select the display mode. Mainly, this selection determines the display mode after switching on the unit. During normal operating mode, the + and – keys are preferably used to switch to the next display mode.

The available display modes depend on the selected source :

<u>“Source = MTD”</u>	<u>Source = NTP</u>
Local	Local
Real-Time	NTP Time
Date	NTP Date
Timer A	
Timer B	
Timer C	
Timer D	
Timer E	
Timer F	
Main 1	
Main 2	
Main 3	
Time code	

Refer to the chapters at “Operating Modes → The Display Modes” for a detailed description of the individual modes.

## Brightness

Brightness of the displays and the lamps in the keys.

Digits	Steps 1 to 7 to adjust the brightness of the LED display.
OLED	Steps 1 to 7 to adjust the brightness of the OLED display. Because the lifespan depends on the brightness, it is recommended to choose the brightness just suitable, not too bright. With <b>lock</b> clicked, this brightness follows the brightness of the "digits".
Keyboard	Steps 1 to 7 to adjust the brightness of the lamps in the keys. With <b>lock</b> clicked, this brightness follows the brightness of the "digits".
Test Displays	All LEDs and lamps will light-up for test purposes.

## Format

Delimiter	Separating sign between pairs of digits of the LED display:	
Auto	"Source = MTD": The type of delimiter will be decoded out of the MTD status data. These data contain the display format setting for each timer, according to the general set-up of the MTD system.	
	"Source = NTP": Time will be displayed as 23:59:59. Date will be displayed as 31.12.10.	
Off	No separating sign:	23 59 59; 31 12 10
. (Decimal Point)	Decimal points:	23.59.59; 31.12.10
: (Colon)	Colons:	23:59:59; 31:12:10
<u>"Source = NTP" only:</u>		
Time	HH:MM:SS 24h	Time display in a 24-hour format.
	HH:MM:SS 12h	Time display in a 12-hour format.
Date	There are several formats provided displaying the date.	
	YY MM DD	Year / Month / Day.
	MM DD YY	Month / Day / Year.
	DD MM YY	Day / Month / Year.
	MM YYYY	Month / Year 4-digits format.
	Day of Year	1 – 365/366.
Time Zone	Select the time zone for the time to be displayed:	
Off	Time of the reference – plus offsets, if <b>Enable Real-Time</b> at the <b>Real-Time</b> tab has been checked.	
Time Zone 1	Time zone 1 – if <b>Enable Real-Time</b> has been checked.	
Time Zone 2	Time zone 2 – if <b>Enable Real-Time</b> has been checked.	

## Screen Saver

A screen saver has been implemented to increase the lifespan of the OLED display. If **active** has been checked, a screen saver program starts when no key has been pressed for the programmed time delay.

## “Timer Names“ Tab: Customize the OLED Text Display

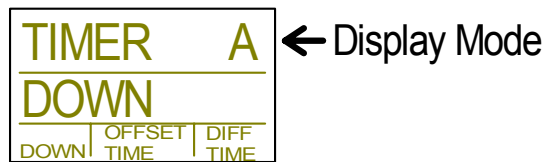
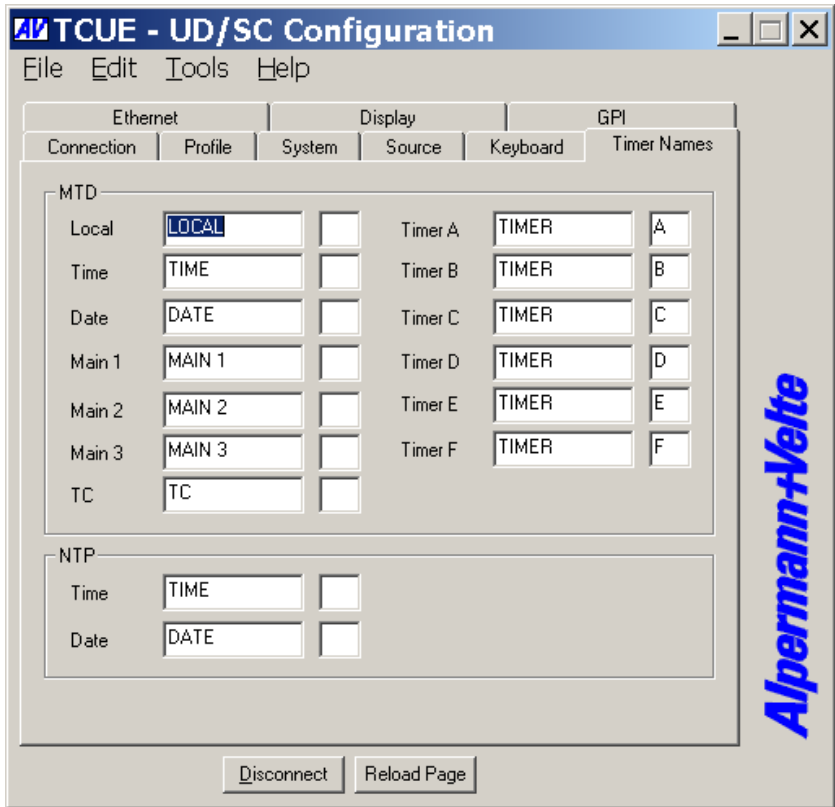

Each display mode can receive a customized text at the OLED display.

This text is divided into two parts: seven characters for a name plus one indicator.

The following characters are available: capital letters A – Z (no umlaut), numbers 0 – 9, and some special characters.

Special characters: ! \* + , - . / : = and space; not permitted characters will be displayed as –.

**MTD:** Relevant if “Source = MTD” has been selected.

**NTP:** Relevant if “Source = NTP” has been selected.

## “Real-Time“ Tab: Set-Up of the NTP Real-Time Parameters

“Source = NTP“ only. Please also refer to chapter “NTP: Time and Date“.

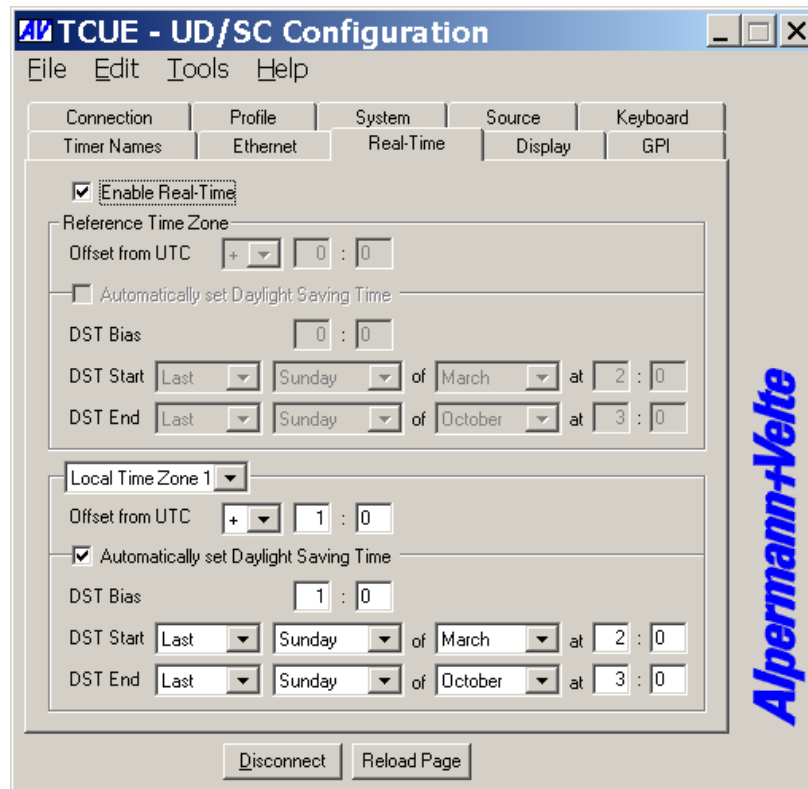

TCUE receives time & date from an NTP server according to the set-up at the “Ethernet“ tab. Time and date refers to UTC (Universal Time Coordinated = world time reference without a Daylight Saving Time [DST]). Having the UTC as a time base, any local time zone can be calculated and displayed.

**Enable Real-Time** Enables or disables the time zone handling.

- If checked, offsets will be calculated and a DST switching can be done automatically.
- If not checked, the displayed time corresponds to the reference time without offset.

**Local Time Zone 1 / 2** Local time zone will be defined with respect to UTC. TCUE H1 with a second display can display different time zones; therefore two time zones can be programmed independently. Which time the unit displays at the end will be selected at the “Display“ tab.

**Offset from UTC** Sign and hours/minutes offset for standard time (winter time).

If the time zone has a DST period, the following parameters should be programmed:

**Automatically set Daylight Saving Time** Check this box if the reference input has a DST period.

**DST Bias** Enter the DST correction value. Most of the cases the correction value will be (+) one hour.

**DST Start** Using these inputs (e.g. last Sunday of March at 2 o’clock) the device calculates the start of DST for the current year.

**DST End** Using these inputs (e.g. last Sunday of October at 3 o’clock) the device calculates the end of DST for the current year.

## “GPI” Tab: Programming GPI Inputs and Outputs

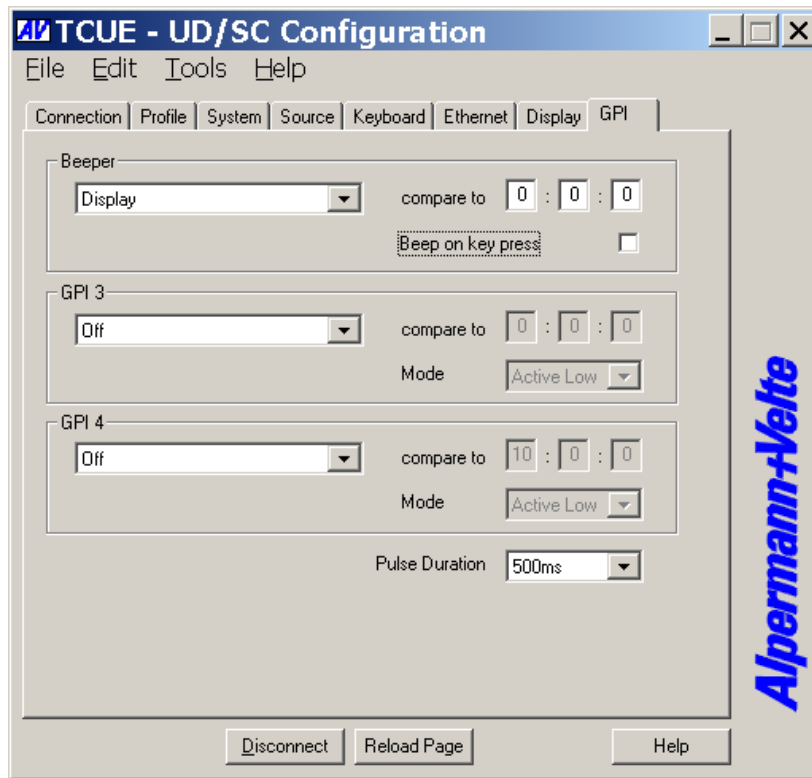

TCUE has two GPI inputs (**GPI 1** and **GPI 2**) and two GPI outputs (**GPI 3** and **GPI 4**). Select the functions from the drop-down lists. For technical details please refer to chapter “Specifications”.

### GPI 1 and GPI 2: Inputs

Available functions: Please refer to chapter “Programming Function Keys and GPI Inputs”.  
Selecting any function will activate the “mode” box:



**Mode:** “Active Low” (please refer to chapter “Specifications” for technical details).

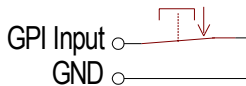

Example: Function becomes active if input state changes from “open” to “closure to GND”.

“Active High” (please refer to chapter “Specifications” for technical details).

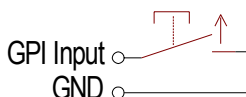

Example: Function becomes active if input state changes from “closure to GND” to “open”.

If one GPI input has “Mode = Active Low” and another “Mode = Active High”, both functions can be executed alternatively with only one signal:

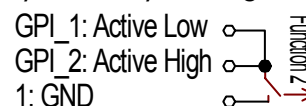

## GPI 3 and GPI 4: Outputs

Output functions work as a time comparator. A fixed time value entered at the **compare to** entries will be compared with the time of the display or the time of a selected timer. A match leads to an impulse output. The pulse duration is adjustable.

Selecting any output function will activate the “compare to” and “mode” boxes:

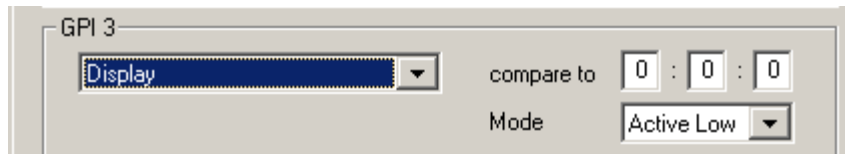

**compare to:** Select hours (0 – 23) : minutes (0 – 59) : seconds (0 – 59).

**Mode:** “Active Low” or “Active High” mode, please refer to chapter “Specifications”.

The drop-down list offers different items depending on the selection at “Source”. The “Display” function compares the current time shown at the display. All other functions compare the selected timer or the selected time – no matter of the display mode.

Functions – dependent on “Source” selection:

<i>Function</i>	<i>Description</i>	<i>available for “Source”</i>
<b>Display</b> TCUE with 2 Displays: Display 1 Display 2	Time comparison with the time currently shown at the display.	MTD NTP
<b>Local</b>	Time comparison with local (internal) stop timer.	MTD NTP
<b>Real-Time</b>	Time comparison with real-time (= time of local time zone).	MTD
<b>Time UTC</b>	Time comparison with NTP reference.	NTP
<b>Time Zone 1</b> <b>Time Zone 2</b>	If real-time operating mode has been selected: Time comparison with the time of the selected time zone.	NTP
<b>Timer A ... F</b>	Time comparison with selected timer A ... F.	MTD
<b>Main 1 ... 3</b>	Time comparison with selected “Main Timer” 1 ... 3.	MTD
<b>Time code</b>	Time comparison with the time shown at display mode “Time code”. Please also refer to chapter “Time Code (TC)”.	MTD

## **Pulse Duration**

GPI output pulse duration: 100/200/500 ms, 1 second, or 2 seconds.

## Programming Function Keys and GPI Inputs



### Remark to the lenses of the keys:

It is not provided to remove the lens of a key afterwards. If you try to remove the lens, the key probably will suffer damage. If you want to change the labelling in the key, please contact *Alpermann+Velte*.

### Detailed information to timer operating modes, "main" timer functions, display formats ...

Please refer to "**The MTD System – Installation and Operation Manual**".

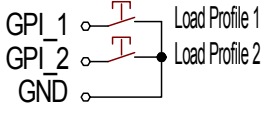
### "Load Profile" functions and applications

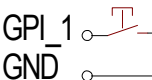
Dropdown list	OLED text	Description
Load Profile 1 Load Profile 2 Load Profile 3 Load Profile 4 Load Profile 5	LOAD PROF 1 (2..) or LOAD "Name"  if a name has been entered before storing	<p>The "Load Profile" function enables to change the complete set-up in a comfortable way.</p> <p>Please notice chapter "Profile Tab: ..." as well.</p> <p>Please remember to program all GPIs and function keys correctly before you execute a "Store Profile".</p> <p>Example 1 – GPI application: Two different signals/buttons recall two different set-ups. <u>Each</u> set-up has all GPI inputs configured as follows: GPI 1 = Load Profile 1, "Mode = Active Low"; GPI 2 = Load Profile 2, "Mode = Active Low".</p>  <p>Example 2 – GPI application: One signal/switch changes over from first set-up to second. <u>Both</u> set-ups have GPIs configured as follows: GPI 1 = Load Profile 1, "Mode = Active <u>H</u>igh"; GPI 2 = Load Profile 2, "Mode = Active <u>L</u>ow".</p> <p>Switch open:      Switch closed:</p>  <p>Example 3 – GPI application: One signal/button recalls five different set-ups one after another. The set-ups have GPIs configured as follows: Profile 1: GPI 1 = Load Profile 2, "Mode = Active Low". Profile 2: GPI 1 = Load Profile 3, "Mode = Active Low". Profile 3: GPI 1 = Load Profile 4, "Mode = Active Low". Profile 4: GPI 1 = Load Profile 5, "Mode = Active Low". Profile 5: GPI 1 = Load Profile 1, "Mode = Active Low".</p> 

## General functions

more suitable for function keys **(F)** or GPI inputs **(G)**, respectively

Dropdown list	OLED text	Description
No Operation		No function
+	+	Plus: Switch to next display mode
-	-	Minus: Switch to previous display mode
Beep Program	BEEP PGM	Start beeper programming <b>(F)</b>
Beep On/Off	BEEP ON/OFF	Beeper on/off. Any change will not be stored non-volatile. After power-on, the mode will be the same as selected at set-up.
GPI3 Program	GPI3 PGM	Programming GPI3 output: <b>(F)</b> Press GPI3 PGM, enter a time value, store with GPI3 PGM. GPI3 PGM and key RESET afterwards disables GPI3 output.
GPI4 Program	GPI4 PGM	Programming GPI4 output – same way as GPI3 PGM

## Stop timer commands

### Local timer and timer A – F commands

more suitable for function keys **(F)** or GPI inputs **(G)**, respectively

Dropdown list	OLED text	Description
Start	START	START command
Stop	STOP	STOP command
Reset	RESET	RESET command
Hold	HOLD	HOLD command: Display freezes last value
Start / Stop	START STOP	Toggles START and STOP command
Reset+Start	RESET START	RESET + START with one command
Reset + Continue	RESET CONT	RESET command if selected timer stays in stop mode. RESET + START command if selected timer is running.
Up	UP	Stop timer function, up-counting <b>(F)</b>
Down	DOWN	Stop timer function, down-counting <b>(F)</b>
Down+Start	DOWN START	Allows changing from UP to DOWN directly: Enter a preset value, and then press DOWN START. <b>(F)</b>
Offset Plus	OFFSET +	Correct the time of a running timer: <b>(F)</b> Enter a correction value, and then press OFFSET + to add this value to the running time.
Offset Minus	OFFSET -	Correct the time of a running timer: <b>(F)</b> Enter a correction value, and then press OFFSET - to subtract this value from the running time.

Timer A – F operating modes, relevant for source = MTD  
more suitable for function keys

Dropdown list	OLED text	Description
Offset Time	OFFSET TIME	Local real-time + time offset
Offset TC	OFFSET TC	VTR LTC + time offset
Offset TC 0	OFFS TC 0	VTR LTC + time offset: reset offset to 0
Diff Time	DIFF TIME	Time difference: Preset time – local real-time
Diff TC	DIFF TC	Time difference: Preset time – VTR LTC
All	ALL	Simultaneously controlling of all timers with “access rights” = on
Time Table	TIME TABLE	Open/close the time table
Calc	CALC	Calculator to add/subtract time values
DUE	DUE	DOWN/UP/END combination
DUE Next	DUE NEXT	DOWN/UP/END combination + NEXT
Set Next	SET NEXT	Transfer next preset value
Next DUE	NEXT DUE	DOWN/UP/END combination + preset from SET NEXT
Automation	AUTOMATION	Automation control for the selected timer on/off
Automation Enable	AUTOM ENABLE	Automation control for all timers on/off

Change display mode, relevant for source **M** = MTD, **N** = NTP

Dropdown list	OLED text	Description	Source
Local	LOCAL	Switch to local stop timer	<b>M N</b>
Time	TIME	Switch to local real-time	<b>M</b>
Date	DATE	Switch to local date	<b>M</b>
Timer A	TIMER A	Switch to timer A	<b>M</b>
Timer B	TIMER B	Switch to timer B	<b>M</b>
Timer C	TIMER C	Switch to timer C	<b>M</b>
Timer D	TIMER D	Switch to timer D	<b>M</b>
Timer E	TIMER E	Switch to timer E	<b>M</b>
Timer F	TIMER F	Switch to timer F	<b>M</b>
Main 1	MAIN 1	Switch to 1 <sup>st</sup> main timer	<b>M</b>
Main 2	MAIN 2	Switch to 2 <sup>nd</sup> main timer	<b>M</b>
Main 3	MAIN 3	Switch to 3 <sup>rd</sup> main timer	<b>M</b>
Time code	TC	Switch to display mode “Time code”. Please also refer to chapter “Time Code (TC)”.	<b>M</b>
NTP Time	NTP TIME	Switch to real-time = local time based on NTP reference	<b>N</b>
NTP Date	NTP DATE	Switch to date = local date based on NTP reference	<b>N</b>

Change "main" timer, relevant for source = MTD

Dropdown list	OLED text	Description
Main 1 = Time	MAIN 1 TIME	1 <sup>st</sup> main timer = local real-time
Main 1 = Date	MAIN 1 DATE	1 <sup>st</sup> main timer = local date
Main 1 = Timer A	MAIN 1 TIMR A	1 <sup>st</sup> main timer = timer A
Main 1 = Timer B	MAIN 1 TIMR B	1 <sup>st</sup> main timer = timer B
Main 1 = Timer C	MAIN 1 TIMR C	1 <sup>st</sup> main timer = timer C
Main 1 = Timer D	MAIN 1 TIMR D	1 <sup>st</sup> main timer = timer D
Main 1 = Timer E	MAIN 1 TIMR E	1 <sup>st</sup> main timer = timer E
Main 1 = Timer F	MAIN 1 TIMR F	1 <sup>st</sup> main timer = timer F
Main 2 = Time	MAIN 2 TIME	2 <sup>nd</sup> main timer = local real-time
Main 2 = Date	MAIN 2 DATE	2 <sup>nd</sup> main timer = local date
Main 2 = Timer A	MAIN 2 TIMR A	2 <sup>nd</sup> main timer = timer A
Main 2 = Timer B	MAIN 2 TIMR B	2 <sup>nd</sup> main timer = timer B
Main 2 = Timer C	MAIN 2 TIMR C	2 <sup>nd</sup> main timer = timer C
Main 2 = Timer D	MAIN 2 TIMR D	2 <sup>nd</sup> main timer = timer D
Main 2 = Timer E	MAIN 2 TIMR E	2 <sup>nd</sup> main timer = timer E
Main 2 = Timer F	MAIN 2 TIMR F	2 <sup>nd</sup> main timer = timer F
Main 3 = Time	MAIN 3 TIME	3 <sup>rd</sup> main timer = local real-time
Main 3 = Date	MAIN 3 DATE	3 <sup>rd</sup> main timer = local date
Main 3 = Timer A	MAIN 3 TIMR A	3 <sup>rd</sup> main timer = timer A
Main 3 = Timer B	MAIN 3 TIMR B	3 <sup>rd</sup> main timer = timer B
Main 3 = Timer C	MAIN 3 TIMR C	3 <sup>rd</sup> main timer = timer C
Main 3 = Timer D	MAIN 3 TIMR D	3 <sup>rd</sup> main timer = timer D
Main 3 = Timer E	MAIN 3 TIMR E	3 <sup>rd</sup> main timer = timer E
Main 3 = Timer F	MAIN 3 TIMR F	3 <sup>rd</sup> main timer = timer F

Change display formats, relevant for source = MTD

Dropdown list	OLED text	Description
Frames	FRAMES	Display format = MM:SS:FF
Nulls	NULLS	Change the 'leading zeros' display directly
Nulls Zero	NULLS ZERO	Change the 'leading zeros at zero transition' display directly
Down Overflow	DOWN OVER	Change the down-counting mode directly: DOWN-STOP or DOWN-OVERFLOW
Neg Flash	NEG FLASH	Change the 'flashing of negative values' display directly

## Firmware Update

Firmware updates require a (windows operating system) computer with a **USB** interface and the **UD SC Config.exe** program. You can download the latest version of the program from: [http://www.alpermann-velte.com/serv\\_e/software\\_e/software\\_e.html](http://www.alpermann-velte.com/serv_e/software_e/software_e.html).

The new firmware should already be stored as a **.tcf** file at your computer.

Please now execute the following steps:

1. Connect the device to the computer with a standard **USB** cable (A – B type). It is recommended not to have more than one device connected to this USB port.
2. Execute **UD SC Config.exe** on your computer. The program gives a list of all devices found. Click (not a double click) on the device in the list which shows the **USB** connection.

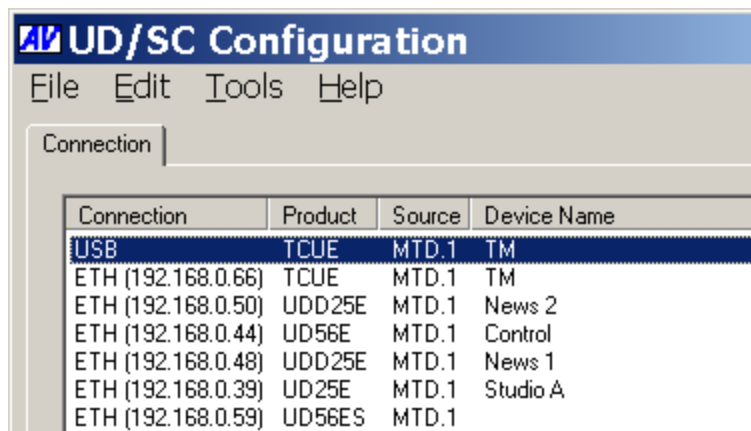

3. Select "Flash Update" in the **File** menu.
4. Open the **.tcf** file. The program checks whether the new firmware matches the correct type of the device. In case there is no match an error message appears: "Incompatible Flash Update File". Update starts automatically if everything is ok. Click the OK button at the end.

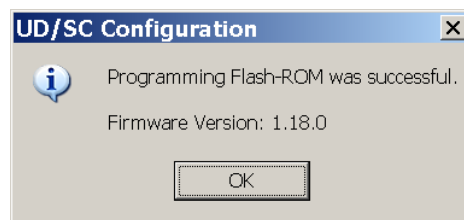

5. Update is finished now. We recommend checking the configuration of the device.

*During the flash update the operation of the device stops!*

## Technical Data

### Connections at the Rear

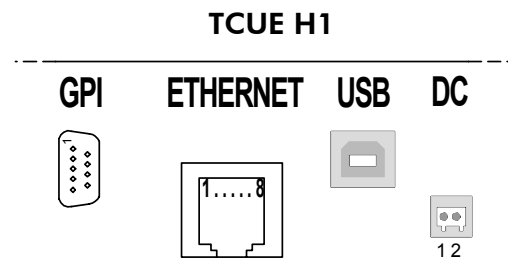
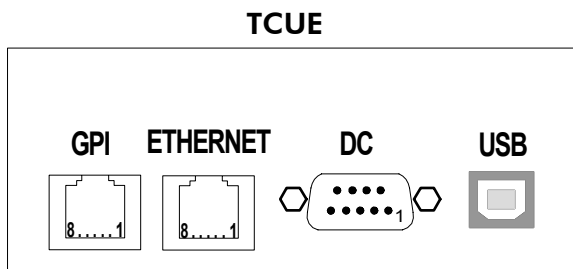

#### Pin assignments:

TCUE			TCUE H1		
GPI RJ45 jack	ETHERNET RJ45 jack	DC DSUB9 male	GPI DSUB9 female	ETHERNET RJ45 jack	DC Terminal Block
1: GND	1: Tx+ / V <sub>PoE+</sub>	1: -	1: -	1: Tx+ / V <sub>PoE+</sub>	1: V-
2: GPI_1	2: Tx- / V <sub>PoE+</sub>	2: -	2: -	2: Tx- / V <sub>PoE+</sub>	2: V+
3: GND	3: Rx+ / V <sub>PoE-</sub>	3: -	3: GPI_1	3: Rx+ / V <sub>PoE-</sub>	
6: GPI_2	4: V <sub>PoE+</sub>	4: -	4: GPI_2	4: V <sub>PoE+</sub>	
4: GND	5: V <sub>PoE+</sub>	5: -	5: GPI_3	5: V <sub>PoE+</sub>	
5: GPI_3	6: Rx- / V <sub>PoE-</sub>	6: V-	6: GPI_4	6: Rx- / V <sub>PoE-</sub>	
7: GND	7: V <sub>PoE-</sub>	7: V-	7: -	7: V <sub>PoE-</sub>	
8: GPI_4	8: V <sub>PoE-</sub>	8: V+	8: -	8: V <sub>PoE-</sub>	
		9: V+	9: GND		

#### Signal descriptions:

GND	Signal ground.
GPI_1, GPI_2	Programmable General Purpose Interfaces: <u>Inputs</u> .
GPI_3, GPI_4	Programmable General Purpose Interfaces: <u>Outputs</u> .
V-, V+	Power supply input: V- = GND V+ = DC voltage input
USB	Connect a standard USB cable: A – B type.

## Specifications

### GPI\_1, GPI\_2

Input specification	Input "Low": -12.0 to +0.7 V Input "High": +2.0 to +24.0 V Impedance: 4.7 kΩ Frequency: 0 - 1 kHz
---------------------	--

### GPI\_3, GPI\_4

Output specification	Open Collector output of a NPN transistor. Max. power dissipation: 200 mW.  "High" state: open collector. If necessary, a pull-up resistor may be connected externally to a positive power source of ≤ 24 VDC, typically 1 kΩ @ +5 VDC.  "Low" state: output switched to GND. Max. collector current: 100 mA DC, fused by a 100 mA auto-recovery fuse. Collector-emitter saturation voltage: @100 mA: typ. 200 mV (≤ 600 mV), @10 mA: typ. 90 mV (≤ 250 mV).  Frequency: 0 - 1 kHz.
----------------------	---

### OLED display module:

Dimensions	58 (W) x 35 (H) x 11 (D) mm
Display Format	128 columns x 64 rows
Pixel Size	0.255 x 0.255 mm
Display Diagonal	1.6"
Active Area	36.46 (B) x 18.22 (H) mm
Color	Monochrome yellow
Grey Scale	4 bits
Brightness	Adjustable, 7 steps (increments)

### Others:

Operating voltage	Supply via DC: V+ = 10 – 30 VDC Supply via PoE: V+ = 36 – 57 VDC
Power consumption	TCUE: 5.2 W maximum, 3.0 W typical. TCUE H1: Including 2 <sup>nd</sup> display: 7.8 W maximum, 4.5 W typical.
Environmental characteristics, operating	Temperature: 5 °C – 40 °C Relative humidity: 30 % - 85 %, non-condensing
Environmental characteristics, non-operating	Temperature: -10 °C - +60 °C Relative humidity: 5 % - 95 %, non-condensing

## Mechanical

### Desktop Housing

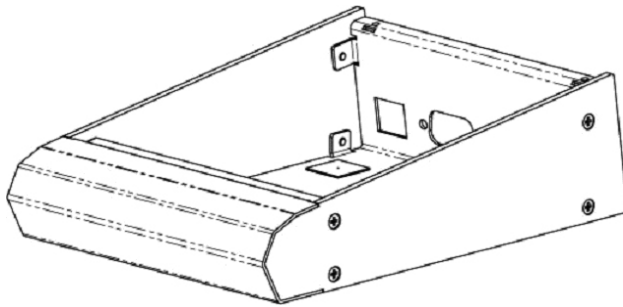

Material	Aluminium, rear plate made of steel
Dimensions	112 (W) x 49 (H) x 161 (D) mm; 4.41 (W) x 1.93 (H) x 6.34 (D) inches
Weight	<math>\approx 0.6\text{ kg}</math>

### Module in a 19" 3 RU Housing

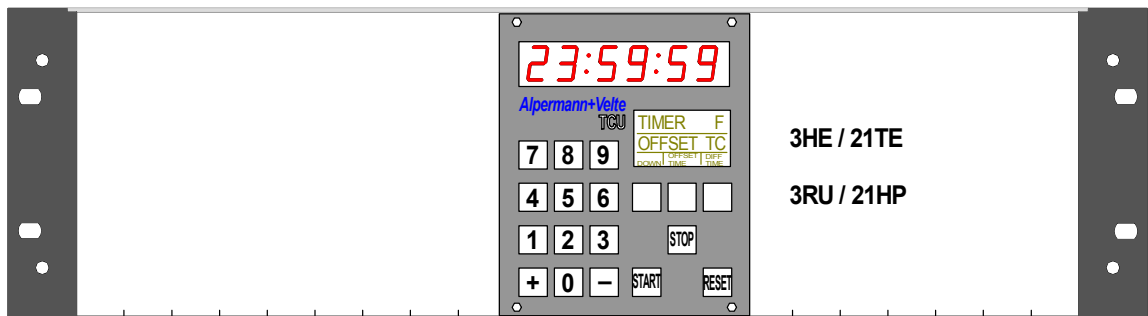

### Special Table Top Mounting

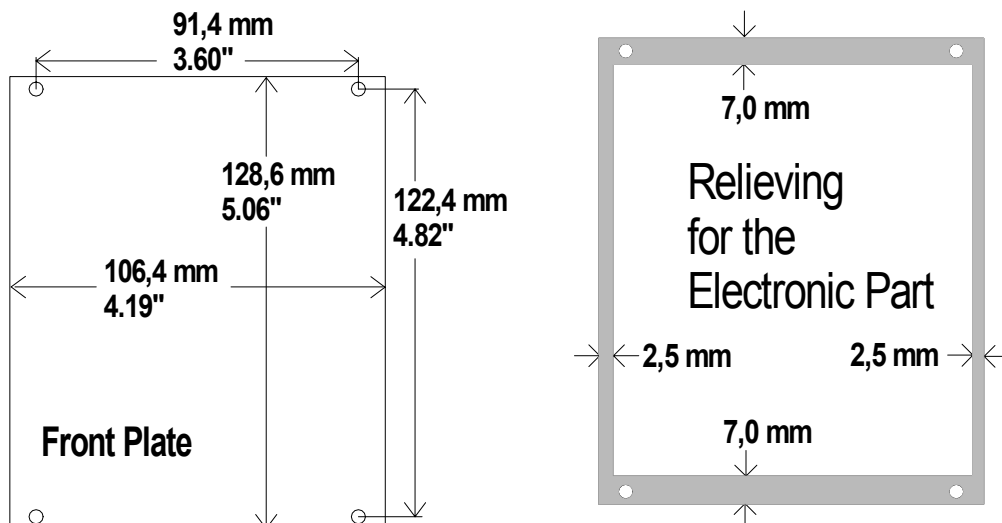

Front plate	Aluminium, thickness 2.9 mm. Four drilled holes $\varnothing$ 2.2 mm, use countersunk head screws.
-------------	---

## 19" 1 RU Version: TCU H1

Front view:



Rear view:

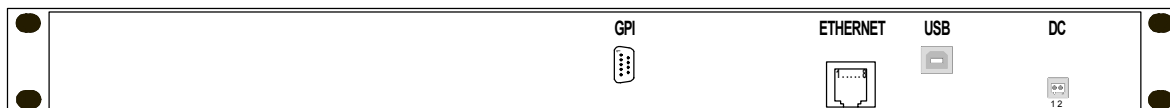

Material	Front plate: Aluminium, thickness 3.0 mm. Electronic box: Sheet metal, thickness 0.6 mm.
Dimensions of the front plate	19", 1 RU
Dimensions of the electronic box	448 (W) x 41 (H) x 25 (D) mm; 17.64 (W) x 1.61 (H) x 0.98 (D) inches
Weight	< ≈ 0.5 kg

## TCU-EP and UD-EP: Power Adapters

### Description and Technical Data

The "TCU-EP" AC/DC adapter is an accessory for *TCU*.

The "UD-EP" AC/DC adapter is an accessory for *TCU H1*.

Both power adapters have a fully enclosed plastic case, a three pole AC inlet according to IEC/EN 60320-1/C14 protection class 1, and a DC output cable with a connector suitable to connect to the DC input of the unit. The power supply cord must match the AC outlet of your country and is not part of the delivery.

**TCU-EP → TCUE**



**UD-EP → TCUE H1**



Please notice the following specifications:

Input	100 - 240 VAC / 0.6 A / 47 - 63 Hz
Output	24 VDC, 850 mA, 20 W max.
Length of output cable	115 cm / 45.3 in
Dimension (W x H x D)	50 x 30 x 110 mm / 1.97 x 1.18 x 4.33 in
Weight	165 g (incl. output cable)
Environment	Operating: temp. 0 °C - 40 °C, humidity 20 % - 80 % Storage: temp. -20 °C - +85 °C, humidity 10 % - 95 %
Safety standards	EN60950, UL listed

## Safety Precautions

The general safety information in this part is for both operating and service personnel. Alpermann+Velte products and accessories are only to be used as directed. Review the following safety instructions to avoid injury and prevent damage to the product or any products connected to it.

### RECOMMENDED INSTALLATION



1. Make sure that the power cord is not inserted when you plug the DC output connector to the terminal block of your device.
2. Insert the power cord into the three pole AC inlet of the AC/DC adapter.
3. Plug the power cord into the wall outlet.

### WARNING



Use a power supply cord that matches the power supply voltage of the AC power outlet. The power supply cord you use must have been approved by and comply with the safety standards of your country.

Never modify the power cord or excessively bend, twist, or pull it. Do not place any heavy objects on the power cord or expose it to heat. Damage to the cord may cause shock or fire.

Use only the AC adapter specified for the Alpermann+Velte product. Never use a voltage other than that for which the AC adapter is rated.

Do not place any objects onto the AC adapter and do not use the AC adapter outdoors. Keep the AC adapter away from heat sources.

Never touch the AC adapter while your hands are wet. To avoid injury or fire hazard, do not operate in an explosive atmosphere.

Immediately unplug the power cord from the wall outlet or extension cord and refer servicing to qualified servicing personnel, when the power cord or plug is damaged, split or broken.

### CAUTION



Do not expose the AC adapter to dripping or splashing water.

Make sure that the power cord is fully inserted into the wall outlet or extension cord.

Make sure that you unplug the AC adapter from an outlet before attempting to move it to another location.

Always carefully disconnect the plug by pulling on the plug and not on the cord.

### PREVENTIVE MAINTENANCE, QUALIFIED SERVICE PERSONNEL ONLY



Visually inspect the AC adapter for signs of damage. If you discover heat damage, try to determine the cause of the overheating before replacing the AC adapter; otherwise, the damage may repeat.

At least once a year, unplug the AC adapter from the power outlet and clean the area around the prongs of the plug. Dust accumulated around the prongs - especially under high humidity conditions - can result in fire.